



ARMYLOR®  
PTFE / PFA  
LINED PIPES  
AND FITTINGS  
DIN 2848



# CONTENT

EXPERTISE **p.1**

MERSEN ANTICORROSION EQUIPMENT **p.2**

PTFE / PFA POLYMERS **p.3**

PTFE / PFA LINING **p.4**

STEEL PARTS **p.7**

LINED COMPONENTS **p.9**

QUALITY CONTROL **p.10**

INSTALLATION PROCEDURES **p.11**

CODING SYSTEM AND REFERENCES **p.13**

MANUFACTURING PROCESS **p.14**

PRODUCTS **p.15**

## EXPERTISE

Mersen has an engineering team dedicated to customer services.

Our experts help study the best technical & economical solutions for your projects. This team can also assist our customers to produce isometric drawings in order to create a list of fittings / components.

The specification or data herein contained are only given for indication, without any undertakings whatsoever. Their publication does not suggest the matter is free of any rights whatsoever. Furthermore, due to constant evolution of techniques and norms, we reserve the right to modify, at any time, the characteristics and specifications contained in this document.

MERSEN refuses all and any responsibility concerning their use whatever the purpose or application. Any copy, reproduction or information herein contained, in whole or in part, made without MERSEN written consent, is forbidden according to the laws of France and particularly the law nr. 92-597 of July 1st 1992 relating to the copyright.



# MERSEN ANTICORROSION EQUIPMENT



















The Mersen AntiCorrosion Equipment activity is internationally recognized for its expertise in the design and manufacture of process equipment, manufactured from corrosion resistant materials (graphite, silicon carbide, tantalum, zirconium, PTFE).

Mersen also has an in-depth knowledge of the process technologies requiring our AntiCorrosion Equipment and can provide offers from the basic equipment only, up to skid-mounted turn-key process packages.

Since 1964, Mersen has been offering an exhaustive range of PTFE / PFA lined pipe and fittings especially designed for conveying corrosive fluids in both the chemical and pharmaceutical industries.

## THE PRODUCT RANGE CONSISTS OF :

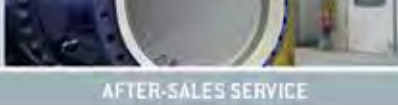
- PTFE / PFA lined pipe and fittings
- PTFE bellows (expansion joints) and compensators
- Manifolds
- Dip pipes
- Double jacketed piping
- Custom made parts

	HEAT EXCHANGERS	REACTORS, VESSELS AND COLUMNS	PIPING BELLOWS ACCESSORIES	PROCESS TECHNOLOGIES																								
GRAPHITE	 BLOCKS, CUBIC AND TUBES		 RUPTURE DISCS	 <b>FEEDSTOCK</b> <table border="1"> <tr><td>H<sub>2</sub>SO<sub>4</sub></td><td>Br<sub>2</sub></td></tr> <tr><td>HCl</td><td>P<sub>2</sub>O<sub>5</sub></td></tr> <tr><td>Cl<sub>2</sub></td><td>FeCl<sub>3</sub></td></tr> <tr><td>HBr</td><td>Brine</td></tr> <tr><td>Flue Gas</td><td></td></tr> </table> <b>PROCESS FUNCTIONS</b> <table border="1"> <tr><td>Gas cleaning / Vent treatment</td><td>Distillation/ Desorption/Stripping</td></tr> <tr><td>Organic removal</td><td>Absorption</td></tr> <tr><td>Production</td><td>Burner</td></tr> <tr><td>Temp. Control</td><td>Concentration</td></tr> <tr><td>Vaporizer</td><td>Dilution</td></tr> <tr><td>Vacuum system</td><td>Gas Drying</td></tr> <tr><td>Inorganic removal</td><td></td></tr> </table>	H <sub>2</sub> SO <sub>4</sub>	Br <sub>2</sub>	HCl	P <sub>2</sub> O <sub>5</sub>	Cl <sub>2</sub>	FeCl <sub>3</sub>	HBr	Brine	Flue Gas		Gas cleaning / Vent treatment	Distillation/ Desorption/Stripping	Organic removal	Absorption	Production	Burner	Temp. Control	Concentration	Vaporizer	Dilution	Vacuum system	Gas Drying	Inorganic removal	
H <sub>2</sub> SO <sub>4</sub>	Br <sub>2</sub>																											
HCl	P <sub>2</sub> O <sub>5</sub>																											
Cl <sub>2</sub>	FeCl <sub>3</sub>																											
HBr	Brine																											
Flue Gas																												
Gas cleaning / Vent treatment	Distillation/ Desorption/Stripping																											
Organic removal	Absorption																											
Production	Burner																											
Temp. Control	Concentration																											
Vaporizer	Dilution																											
Vacuum system	Gas Drying																											
Inorganic removal																												
SILICON CARBIDE	 BLOCKS AND TUBES																											
TANTALUM	 TUBES AND BAYONETS		 TANTALUM SMALL PARTS																									
ZIRCONIUM	 TUBES AND BAYONETS																											
TITANIUM	 TUBES AND BAYONETS																											
NICKEL ALLOYS	 TUBES AND BAYONETS																											
PTFE			 PIPING AND BELLOWS																									
	<b>AFTER-SALES SERVICE</b>																											

# PTFE / PFA POLYMERS

## DEFINITION

Available lining materials for our product range are as follows :

- ▶ **Virgin or anti-static\* PTFE (Polytetrafluoroethylene), in accordance with ASTM D4894 & 4895 standards.**
- ▶ **Virgin or anti-static\* PFA (perfluoroalkoxy), according to ASTM D3307\*\* standard.**

\* Conductive black PTFE or PFA

\*\* Also on request according to DIN 53455 standard

## GENERAL CHARACTERISTICS

Values indicated in the following table are given for virgin PTFE and PFA.

These characteristics can vary depending on the material grades from the various suppliers, the transformation process and the batch.

PROPERTIES	UNITS	PTFE	PFA
<b>Physical</b>			
Density	g/cm <sup>3</sup>	2.13 - 2.19	2.12 - 2.17
Water absorption : 24h thickness 3,2 mm	%	<0.01	0.03
<b>Mechanical</b>			
Tensile strength	MPa	20 - 40	27 - 32
Elongation at break	%	250 - 500	300 - 500
Modulus of elasticity under elongation	MPa	350 - 750	650 - 700
Modulus of elasticity under flexural stress	MPa	440 - 670	590 - 700
Hardness shore D mandhod		50 - 72	60 - 65
<b>Thermal</b>			
Flame propagation		hard	hard
Melting point	°C	327 and 342	300 to 310
Other transitions	°C	-90*,+123,* +27**	-80*, 90*
Maximum service temperature	°C	-200/+260	-150/+260
Temp. of deflection under load (1.82 MPa)	°C	50 - 60	50
Linear elongation coefficient	10 <sup>5</sup> / °C	10 - 25	12
Thermal conductivity	W / m.K	0.24	0.25
<b>Electrical</b>			
Dielectric constant from 60 Hz to 107 Hz		2.2	2.1
Volume resistivity	Ω.cm	10 <sup>18</sup>	10 <sup>18</sup>
Surface resistivity	Ω	10 <sup>17</sup>	10 <sup>17</sup>
Spark test (thick.mm)	kV / mm.K	36(1)	80(2.3)

\*amorphous phase, \*\*crystal phase

## RECEIVING INSPECTIONS

Material certificates from the PTFE / PFA powder manufacturers are checked and identified with batch numbers. On request, FDA certificates (Food and Drug Administration) can be supplied.

# PTFE / PFA LINING

## NOMINAL THICKNESSES

Mersen proposes 3 ranges of PTFE / PFA thicknesses :

- ARMYLOR® G to operate under pressure
- ARMYLOR® V to operate under pressure and vacuum
- ARMYLOR® S for severe applications [Ask us](#)

} Thicknesses G and V are indicated in the table below

## PTFE / PFA NOMINAL THICKNESS

DN	SPOOLS		ELBOWS		TEES		CONC. / EXC. RED.		INSTRUMENT TEES		MANIFOLDS	
	G	V	G	V	G	V	G	V	G	V	G	V
15		3.0		3.0		3.0		3.0		3.0		3.0
20		3.0		3.0		3.0		3.0		3.0		4.0
25		3.0		3.3		3.0		3.5		3.0		4.0
32		3.0		4.0		3.3		3.5		3.3		5.0
40		3.0		4.0		3.5		3.5		3.5		6.0
50		3.0		4.0		3.5		3.5		3.5		7.0
65		3.0	3.5	4.0		4.0		3.5		4.0		7.0
80	3.0	3.5	3.5	4.5		4.5		4.0		4.0		9.0
100	3.0	4.2	4.0	7.5		5.0		5.0		5.0	5.0	10.0
125	3.0	5.0	4.8	8.0	5.0	9.0		5.0		5.0	6.0	10.0
150	4.0	5.3	5.0	9.5	6.0	10.0	5.0	5.3		6.0	6.0	11.0
200	4.0	6.2	7.0	10.0	6.0	12.0	6.0	6.2		8.0	7.0	12.0
250	4.0	7.0	7.0	11.0	7.0	12.0	6.5	7.0	7.0	12.0	7.0	12.0
300	4.0	8.0	7.0	12.0	7.0	12.0	6.5	8.0	7.0	12.0	7.0	12.0
350	4.5		8.0		8.0		8.0		8.0			
400	4.5		6		6		6		6			
450	4.5		6		6		6		6			
500	4.5		6		6		6		6			
600	4.5		4.5		4.5		4.5		4.5			

The minimal thickness of the PTFE tube is equal to the nominal minus 10% - The thickness of the flare cannot be lower than the nominal thickness, minus 20%.

## TESTS ON PTFE / PFA

### Physical and mechanical tests

For each manufacturing batch, Mersen checks the mechanical & physical properties.

Values for elongation at break point and tensile strength, together with regularity of the graph confirms that the liner sintering has re-established the isotropy of PTFE, which guarantees a low level of permeability.

Parallel direction

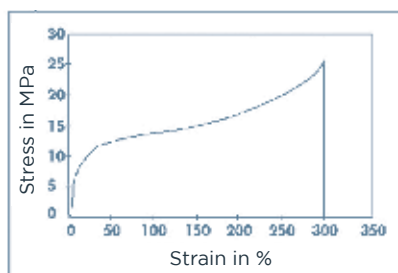

Perpendicular direction

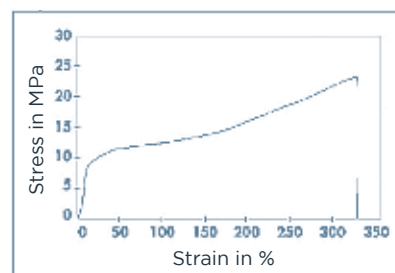

# PTFE / PFA LINING

Optimal density ensures a balance between a low permeability level and a good distortion during temperature cycles.

	MECHANICAL PROPERTIES		PHYSICAL PROPERTIES	
	Tensile strength	Elongation at break	Density	
<b>PTFE Extruded</b> Virgin Test according to standard	+ 21 N/mm <sup>2</sup> (// Direction) + 17 N/mm <sup>2</sup> (⊥ Direction) ASTM D4895	+ 250% (// Direction) + 200% (⊥ Direction) ASTM D4895	2.14 - 2.19 ASTM D792	2.13 - 2.19 DIN 53749
Antistatic Test according to standard	+ 21 N/mm <sup>2</sup> (// Direction) + 17 N/mm <sup>2</sup> (⊥ Direction) ASTM D4895	+ 250% (// Direction) + 200% (⊥ Direction) ASTM D4895	2.13 - 2.19 ASTM D792	2.12 - 2.18 DIN 53749
<b>PTFE Molding</b> Virgin Test according to standard	+ 21 N/mm <sup>2</sup> ASTM D4894	+ 250% ASTM D4894	2.14 - 2.19 ASTM D792	2.13 - 2.19 DIN 53749
Antistatic Test according to standard	+ 21 N/mm <sup>2</sup> ASTM D4894	+ 250% ASTM D4894	2.14 - 2.19 ASTM D792	2.12 - 2.18 DIN 53749
<b>PFA</b> Virgin Test according to standard	+ 26 N/mm <sup>2</sup> ASTM D3307	+ 300% ASTM D3307	2.12 - 2.17 ASTM D792	2.12 - 2.17 DIN 53749
Antistatic Test according to standard	+ 26 N/mm <sup>2</sup> ASTM D3307	+ 300% ASTM D3307	2.11 - 2.17 ASTM D792	2.11 - 2.16 DIN 53749

*The results comply with the ASTM F1545 standard*

## ANTISTATIC PTFE / PFA ELECTRICAL PROPERTIES

Transverse resistivity : < 10<sup>7</sup> Ω based on the BS ISO 2878 : 2005 standard

Surface resistivity : < 10<sup>8</sup> Ω based on the BS ISO 14309 : 2011 standard

Volume resistivity : < 10<sup>8</sup> Ω based on the BS ISO 14309 : 2011 standard



Thanks to Mersen's expertise in lining technologies (PFA injection, extrusion of fine PTFE powders, Isomoulding). Mersen has optimised its manufacturing processes and PTFE / PFA thicknesses in order to limit the permeability rate.

## OPTIMIZING THE LINER THICKNESS - PERMEABILITY

SEVERAL FACTORS HAVE AN INFLUENCE :

- ▶ **Thickness of the liner is the most significant factor.** The chart below shows the sharp decrease of permeability versus thickness.
- ▶ **Size of the ions or molecules :** the Helium permeability curve shows the ability of a very small molecule such as helium to pass through the PTFE / PFA.
- ▶ **Chemical nature of the product :** any chemical similarity between the material passing through and the material passed through increases permeability.
- ▶ **Temperature and pressure:** permeability increases with temperature and pressure.

EXAMPLES OF PERMEABILITY CURVES :

PTFE / PFA permeability curve

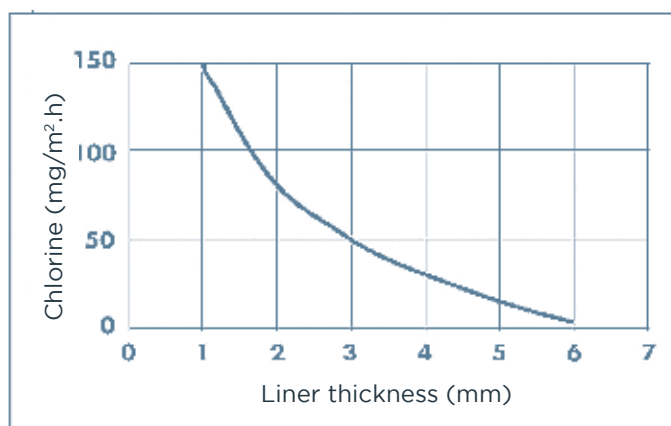

Helium permeability PTFE / PFA curve

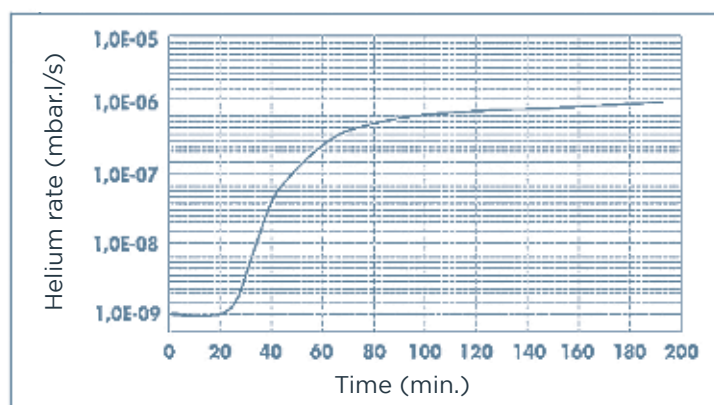

# STEEL PARTS

## COMPONENTS

The table below shows the various steel components used for manufacturing our standard pieces. 3.1 mill certificates in accordance with EN 10204 are available on request.

ASTM or JIS standards compliant steel grades, low temperature or stainless steel grades can be supplied on request. Please contact us for more information.

DESCRIPTION	PIPES / BODIES		FLANGES	
	DIMENSIONAL STANDARD	GRADE	DIMENSIONAL STANDARD	MIN. GRADE
SPOOLS	EN 10216	P 235 GH / EN 10216	EN 1092	P 245 GH / EN 10222
ELBOWS	EN 10253	P 235 GH / EN 10216	EN 1092	P 245 GH / EN 10222
CAST STEEL ELBOWS AND TEES		GP 240GH		
TEES AND CROSSES	EN 10216	P 235 GH / EN 10216	EN 1092	P 245 GH / EN 10222
CONCENTRIC REDUCERS	EN 10253	P 235 GH / EN 10216	EN 1092	P 245 GH / EN 10222
REDUCING FLANGES			EN 1092	P 245 GH / EN 10028
SPACERS				P 245 GH / EN 10028
INSTRUMENT TEES	EN 10216	P 235 GH / EN 10216 / EN 10028	EN 1092	P 245 GH / EN 10222



## WELDING

Mersen is qualified in accordance with the European standards EN ISO 15614-1 (for WPQR's) and EN ISO 9606-1 (for WPQ's), with German ADM HP 5.3 and with ASME Section IX for GMAW, FCAW, GTAW and SAW processes. These qualifications are renewed on a regular basis, either by Mersen IWE (International Welding Engineer) or by Third Parties (German TÜV or French Apave). Suppliers' assessments are performed by Mersen in order to make sure that the same quality standards are implemented.

## FLARED STUB ENDS

Spools are built with 2 loose flanges on collars obtained by cold forming of the steel tube, from DN 15 to DN 300. This process has been assessed by Notified Bodies and found compliant with the essential requirements of the PED. A loose flange stop can be supplied on request.

## VENT HOLES

THE STEEL PARTS OF THE PTFE / PFA LINED FITTINGS ARE DRILLED WITH VENT HOLES IN ORDER TO :

- ▶ Prevent any back pressure between the metallic housing and the liner.
- ▶ Detect any leakage during pressure tests.
- ▶ Quickly detect any sign of corrosion.

*Spools with length below 500 mm have one 3 mm diameter vent hole in the middle of the piece. Those above 500 mm are fitted with two vent holes located about 150 mm from each end. The fittings have at least one 3 mm diameter vent hole. Reducing flanges, blind flanges and spacers do not have any vent holes. In the case of particular specifications or thermal insulation piping, vent bosses can be welded to the vent holes.*

## VENT BOSSES

If vent holes must be identified quickly or when the piping is thermal insulated, a coupling can be welded on to the vent holes. In the case of different thermal insulation thicknesses, an extension stem can be screwed on to the coupling.

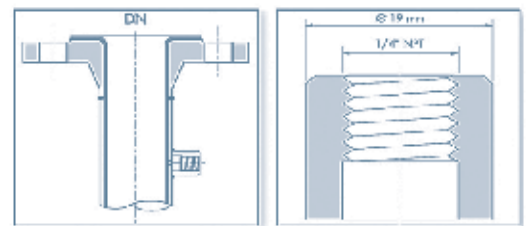

## ELECTRICAL CONTINUITY

The electrical continuity of lined piping can be ensured by connecting each individual component together by using conductors linked to earthing lugs.

The latter are welded in the middle of the steel part for fittings and spools below 500 mm long and at about 150 mm from the back side of each flange for spools above 500 mm long. Types A or B earthing lugs can be proposed on request. Standard materials are 304 or 316 stainless steel grades.

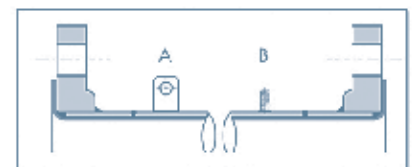

*Other materials can be supplied on request.*

## PAINTING

The standard coating is a 40 µm thick zinc epoxy primer coating on sand blasted steel, in accordance with the S.A 2.5 cleanliness level. Other surface preparations, undercoats or topcoats can be applied on request.

# LINED COMPONENTS

## DIMENSIONAL TOLERANCES

The lined pieces and their dimensions are indicated in pages 17 to 35.  
All the lined pieces are built using the following tolerances :

	DIMENSION	DIMENSIONAL TOLERANCE	ANGULAR TOLERANCE
LENGTHS	0 - 315 mm	+0; -3 mm	± 0.5°
	315 - 1000 mm	+0; -4 mm	± 0.5°
	1000 - 6000 mm	+0; -5 mm	± 0.5°
DIAMETERS	DN 25 - 100	+0; -3 mm	± 0.5°
	DN 125 - 200	+0; -4 mm	± 0.5°
	DN 250 - 600	+0; -5 mm	± 0.5°

*Tolerance for PTFE / PFA : 5%*

## TEMPERATURE CYCLE TESTS

The pieces tested undergo 100 alternate steam / cold water cycles, according to the ASTM F1545 standard. Steam is absorbed by the liner under the influence of both temperature and pressure. Vacuum resistance of the liner is then proved due to significant mechanical stresses caused by the sudden pressure drop combined with fast cooling.

## VACUUM RESISTANCE

DN	15	20	25	32	40	50	65	80	100	125	200	250	300	350	400	
ARMYLOR® G	Vacuum 2 Torr 150° C															
ARMYLOR® V	Vacuum 2 Torr 230° C								Vacuum 2 Torr 150°C		2 Torr 100°C					
ARMYLOR® S									Vacuum according to particular specifications							

*Units : 760 Torrs = 760 mmHg = 1 bar = 1 kg/cm<sup>22</sup> = 10<sup>5</sup> Pa = 14.7 Psi*

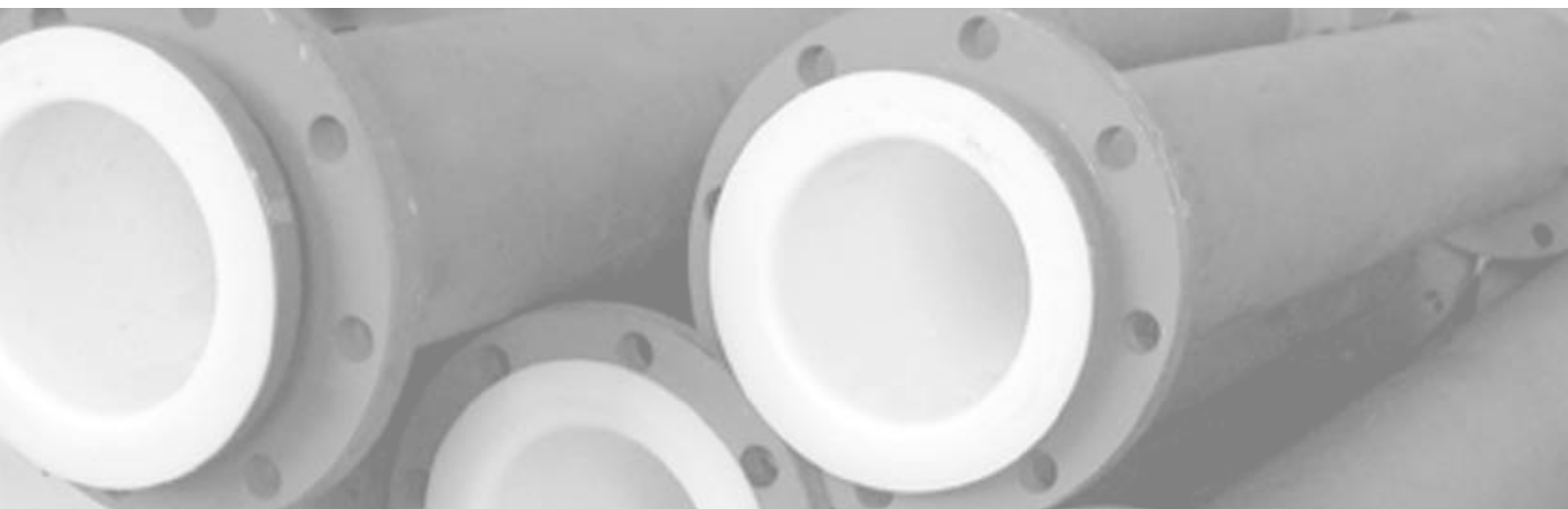

# QUALITY CONTROL

## INSPECTIONS AND TESTS PROGRAM

MERSEN manufactures PTFE-lined piping and fittings compliant with the the European Pressure Equipment Directive 2014/68/UE (previously 97/23/CE). Type agreements are awarded by the APAVE Notified Body (CE 0060) for the whole range of ARMYLOR® products. In addition to assessments carried out by Third Parties and continuous internal audits, a complete inspection and tests program is set during the entire manufacturing process :

- **Raw material (fluoropolymers)** : acceptance criteria at receiving inspections, physical properties of the liners monitored throughout the manufacturing process...
- **Spark tests are performed on each PTFE and PFA-lined piece in the following conditions :**  
voltage of  $5000 * E$  ( $E$  = thickness of liner in mm) with a maximum of 25000 V.
- **Dimensional and visual examination of the liners and steel parts :**  
the weld aspect, the overall dimensions, the size of the collars, the liner thickness, the absence of surface defects and the painting thickness are checked.
- **Non-destructive examinations** are carried out when required by the applicable standards or on request. RT and PT are performed by COFREND level II qualified personnel.
- **Pressure tests** : depending on the lining process, a hydrostatic or a pneumatic test is performed. A hydrostatic test is performed on pieces fitted with vent holes, injected or produced from tubes. A pneumatic test is carried out on isomolded pieces and on some pieces produced from extruded liners.

## TRACEABILITY AND MARKING

IN ADDITION TO THE INSPECTIONS AND TESTS PROGRAM, A FULL TRACEABILITY SYSTEM OF MATERIALS IS IMPLEMENTED :

- ▶ **Steel parts** : a coded marking system with unique traceability to the mill certificates is used. Each piece is cold stamped. Marking transfers by Mersen qualified personnel are approved by Mersen's Notified Body.
- ▶ **Finished product** : the following information is stamped on the finished piece :
  - The initials of Mersen, the order number and the piece number (Manufacturing number)
  - The «CE» symbol followed by the Notified Body registration number when applicable.
- ▶ **Traceability of documents** : total traceability is ensured with the same method for both steel and lining materials.

Coded marking pertaining to mill certificate

Order number + Manufacturing number

CE symbol + Notified Body number (when applicable)

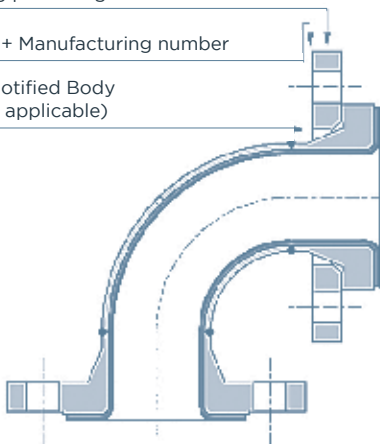

Additional marking can be done.

On request, each part can be identified thanks to a heat transfer printed sticky label that shows piece reference and isometric number.

# INSTALLATION PROCEDURE

Installation and maintenance instructions are provided in the user's manual delivered with the products. Specific items are highlighted here after.

## PRECAUTIONS

The lined steel components are delivered with wooden or plastic blanks installed to protect the PTFE / PFA flange faces. Remove these protective blanks when the components are about to be connected only : they shall be refitted after each inspection and when the piece is withdrawn from the installation. Once the blanks have been removed, the greatest care is required : no contact with the ground, absence of any sharp object that could damage the liner. **Never weld on lined parts.**

## CLEANING

Flared surface must be carefully cleaned prior to connection.

## BOLT TIGHTENING

The assembly of PTFE / PFA lined components does not require any gaskets except when materials of different natures are being coupled or during successive assembling and dismantling operations.

### TIGHTENING BOLTS :

- ▶ **Insert** the washers.
- ▶ **Clean** and grease the bolts.
- ▶ **Tighten** nuts by hands.
- ▶ **Tighten** each bolt using a torque wrench, keeping to the torque values specified in the table beside.
- ▶ Cross-tightening as with any flange connection.

Tightening torque values are given for PTFE / PFA and may vary depending on greasing and the condition of the nuts and bolts.

Values are given for PN 10 flanges. They are indicated for room temperature and must always be checked in cold conditions, after 24 hours of operation, then checked periodically.

### THE TIGHTENING TORQUE VALUES INDICATED BESIDE APPLY TO :

#### Class 8.8 steel nuts

(resistant to 800 N/mm<sup>2</sup> rupture, elasticity limit of 640 N/mm<sup>2</sup>).

0.12. nut friction **coefficient.**

DN	BOLTS mm	TORQUE N.m
DN 25	4 x M12	30
DN 32	4 x M16	45
DN 40	4 x M16	60
DN 50	4 x M16	80
DN 65	8 x M16	100
DN 80	8 x M16	60
DN 100	8 x M16	70
DN 125	8 x M16	90
DN 150	8 x M20	130
DN 200	8 x M20	180
DN 250	12 x M20	160
DN 300	12 x M20	210
DN 350	16 x M20	260
DN 400	16 x M24	330
DN 450	20 x M24	290
DN 500	20 x M24	330
DN 600	20 x M27	460

## BOLT LENGTHS

The table below specifies the recommended lengths of threaded stems for the various assemblies.

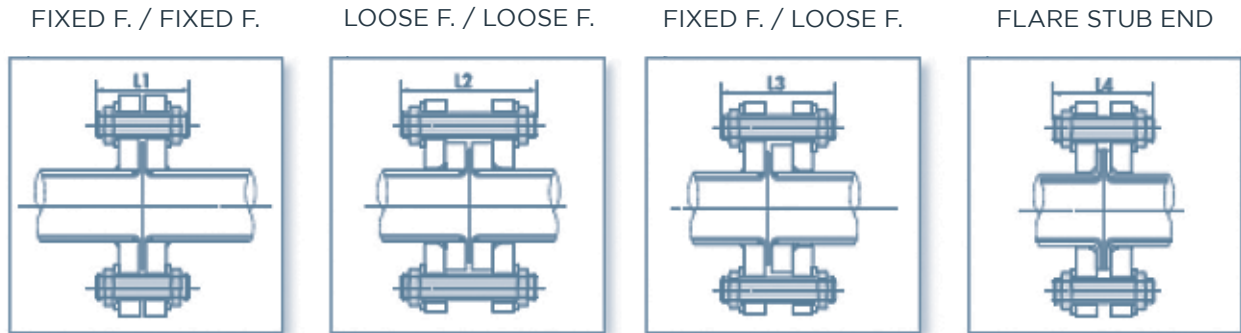

### THE DIMENSIONS INDICATED REFER TO :

- ▶ A tightening torque equal to 1/3 the diameter of the threaded stems.
- ▶ A nut height equal to the diameter of the threaded stems.

## VENT HOLES

Vent holes must not be obstructed by thermal insulation or painting. Where thermal insulation is fitted, vent extensions should be provided. When pipes are operated for the first time, air or water trapped inside at the moment of assembly may escape through the vent holes. It is recommended, during periodic inspection, to check that no trace of leakage is visible around the vent holes. The latter also act as corrosion indicators.

## WEIGHT

The weight (kg) of each piece is indicated on the corresponding tables. Due to the various construction methods, the weights are typical values only. The tolerance is +/- 10%.

## SUPPORTS

Elements must be supported using collars that are not welded on the lined piping. **Never weld on lined parts.** However, supporting elements may be welded prior to lining.

DN	L1 mm	L2 mm	L3 mm	L4 mm
DN 15	75	95	85	
DN 20	80	100	90	
DN 25	80	105	90	85
DN 32	90	115	105	95
DN 40	90	115	105	95
DN 50	95	120	105	95
DN 65	95	125	110	100
DN 80	100	130	115	105
DN 100	105	130	115	115
DN 125	110	135	120	
DN 150	120	150	135	120
DN 200	125	155	140	140
DN 250	130	165	145	145
DN 300	130	175	150	150
DN 350	135	180	155	155
DN 400	160	205	175	
DN 450	170	205	175	
DN 500	170	230	190	
DN 600	170	235	190	

# CODING SYSTEM AND REFERENCES

Each element has its own unique reference which allows its identification. This reference is composed on 16 alphanumeric characters. In some cases, the character can be «-» if refers to standard. The references that are mentioned in the dimensional tables are the standard ones.

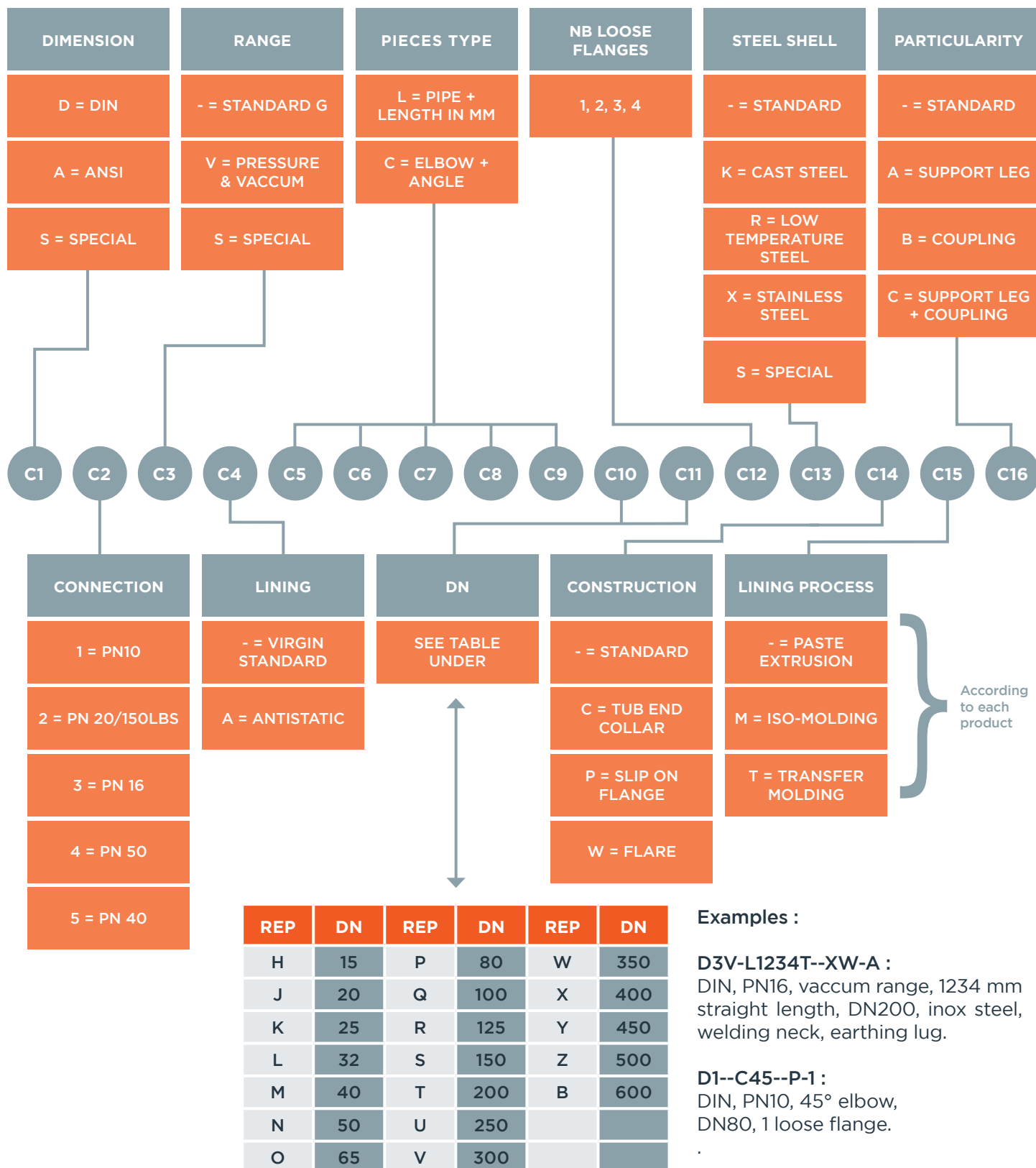

# MANUFACTURING PROCESS

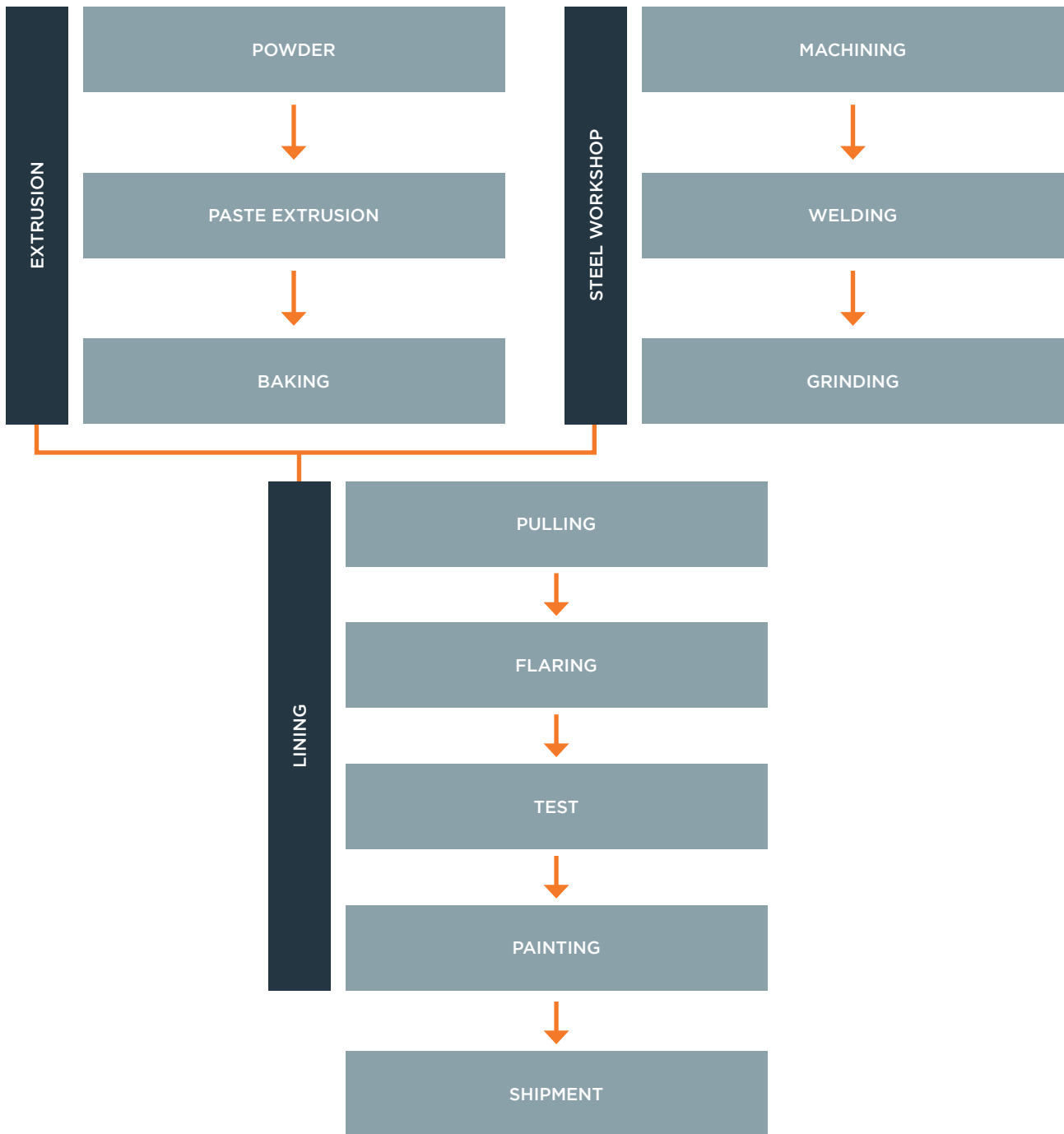

# PRODUCTS DATA SHEETS

DIN FLANGES PN 10 AND PIPES [p.16](#)

FLANGED SPOOLS [p.17](#)

ELBOWS [p.18](#)

EQUAL TEES [p.19](#)

REDUCING TEES [p.20-21](#)

CONCENTRIC & ECCENTRIC REDUCERS [p.22](#)

REDUCING FLANGES [p.23-25](#)

INSTRUMENT TEES [p.26](#)

CROSSES [p.27](#)

SPACERS [p.29](#)

SPECTACLE BLINDS [p.30](#)

BLIND FLANGES & LATERAL TEES [p.31](#)

MANIFOLDS [p.32](#)

DOUBLE JACKETED PIPING [p.33](#)

DIP PIPES & ENTRY PIPES [p.34](#)



# DIN FLANGES PN 10 AND PIPES

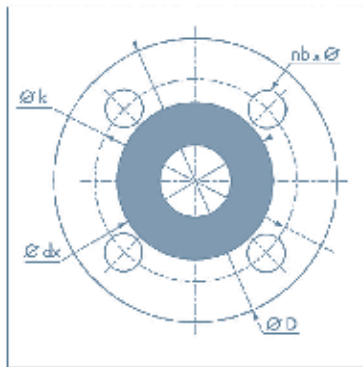

Flange (front view)

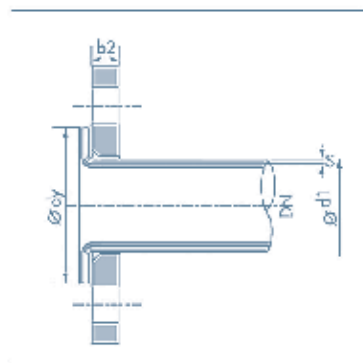

Flared stub end type C (loose)

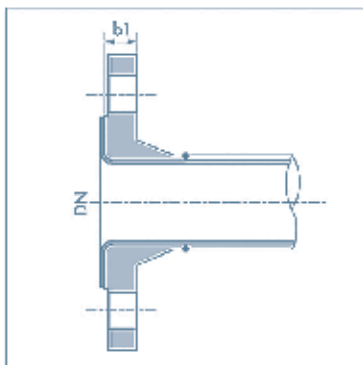

DIN 2632 Welding neck type W (fixed)

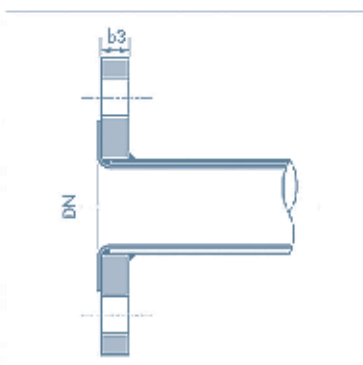

DIN 2576 Slip-on Type P (fixed)

## DIMENSIONAL TOLERANCES

The whole range of flanged products from DN15 to DN600 can be equipped with loose or fixed flanges on request.

DN	DIAMETERS				THICKNESS				DRILLING PN10			STEEL PIPES		
	D	dx*	dy	k	b1	b2	b3	b4	holes		bolting	d1	s	
	mm	mm	mm	mm	mm	mm	mm	mm	nb	x	Ø		mm	mm
15	95	45	45	65	14	14	14	10	4	x	14	M12	26.9	2.3
20	105	58	55	75	16	14	16	12	4	x	14	M12	26.9	2.3
25	115	68	55	85	16	16	16	12	4	x	14	M12	33.7	2.6
32	140	78	67	100	16	16	16	12	4	x	18	M16	42.4	2.6
40	150	88	80	110	16	16	16	12	4	x	18	M16	48.3	2.6
50	165	102	95	125	18	16	18	14	4	x	18	M16	60.3	2.9
65	185	122	118	145	18	16	18	14	8	x	18	M16	76.1	2.9
80	200	138	130	160	20	18	20	16	8	x	18	M16	88.9	3.2
100	220	158	158	180	20	18	20	16	8	x	18	M16	114.3	3.6
125	250	188	188	210	22	18	22	18	8	x	18	M16	139.7	4.0
150	285	212	212	240	22	18	22	18	8	x	22	M20	168.3	4.5
200	340	268	268	295	24	20	24	20	8	x	22	M20	219.1	6.3
250	395	320	320	350	26	22	26	22	12	x	22	M20	273.0	6.3
300	445	370	370	400	26	26	26	22	12	x	22	M20	323.9	7.1
350	505	430	430	460	26	28	28	22	16	x	22	M20	355.6	8.0
400	565	482		515	26	32	32	24	16	x	26	M24	406.4	8.5
450	615	532		565	/	/	38	24	20	x	26	M24	457.2	9.5
500	670	585		620	28	38	38	26	20	x	26	M24	508.0	9.5
600	780	685		725	28	44	40	26	20	x	30	M27	609.6	9.5

\* Tolerance 5%

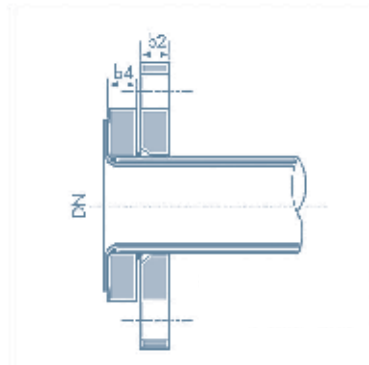

DIN 2642 Collar + slip-on type P (loose)

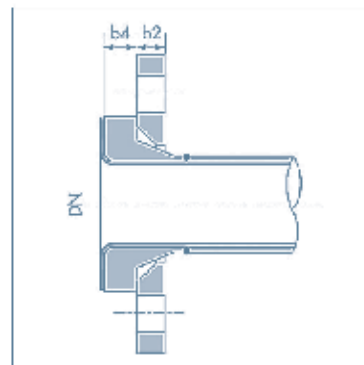

DIN 2673 Collar + slip-on type W

PN6  
PN16  
PN20  
PN25...  
on request

# FLANGED SPOOLS



## LINING

- ▶ VIRGIN PTFE : DN 15 – DN 600
- ▶ ANTISTATIC PTFE, C4 = A : DN 15 – DN 400

### Standard construction : 2 loose flanges

- Type C : DN 15 to DN 300, C14 = C

### On request : 1 fixed flange, 1 loose flange

- Type P : DN 15 to DN 350
- Type W : C14 = W

DN	L min.	L max.	Weight kg/m	Pair flanges weight	REFERENCE															
	mm	mm			1	2	3	4	5	6	7	8	9	10	11	12	13	14	15	16
15	85	6000	1.8	1.4	D	1	-	-	L	x	x	x	x	H						
20	85	6000	1.8	7.9	D	1	-	-	L	x	x	x	x	J						
25	85	6000	2.8	2.5	D	1	-	-	L	x	x	x	x	K						
32	85	6000	3.2	3.7	D	1	-	-	L	x	x	x	x	L						
40	90	6000	3.9	4.2	D	1	-	-	L	x	x	x	x	M						
50	100	6000	5.3	5.5	D	1	-	-	L	x	x	x	x	N						
65	100	6000	6.7	6.7	D	1	-	-	L	x	x	x	x	O						
80	110	6000	9.2	8.4	D	1	-	-	L	x	x	x	x	P						
100	120	6000	12	10	D	1	-	-	L	x	x	x	x	Q						
125	120	6000	16	13	D	1	-	-	L	x	x	x	x	R						
150	120	6000	21	16	D	1	-	-	L	x	x	x	x	S						
200	130	6000	41	23	D	1	-	-	L	x	x	x	x	T						
250	150	6000	56	31	D	1	-	-	L	x	x	x	x	U						
300	150	6000*	63	38	D	1	-	-	L	x	x	x	x	V						
350	150	5000	78	51	D	1	-	-	L	x	x	x	x	W						
400	150	3500	97	65	D	1	-	-	L	x	x	x	x	X						
450	150	6000	104	85	D	1	-	-	L	x	x	x	x	Y						
500	160	6000	133	90	D	1	-	-	L	x	x	x	x	Z						
600	180	4500	161	134	D	1	-	-	L	x	x	x	x	B						

\*For vacuum thickness, L max = 4500 and xxx = length in mm.

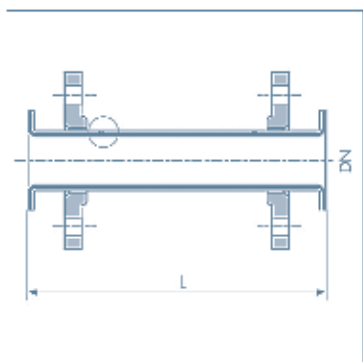

Type C construction

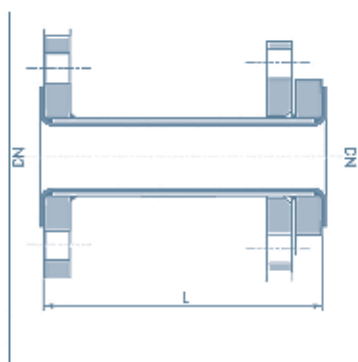

Type P construction

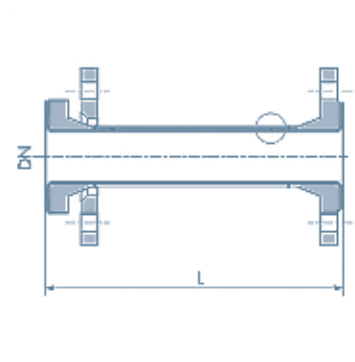

Type W construction

# ELBOWS



LINING

- ▶ VIRGIN PTFE : DN 15 – DN 600
- ▶ ANTISTATIC PTFE, C4 = A : DN 15 – DN 400

### Standard construction : 2 fixed flanges

- Type K : DN 25 to DN 100, C13 = K
- Type W : superior DN 100

### On request : 1 fixed flange + 1 loose flange

- C12 = 1

DN	L (mm)				Weight (kg)				REFERENCE																
	$\alpha=90^\circ$	$\alpha=45^\circ$	$\alpha=60^\circ$	$\alpha=30^\circ$	90°	45°	60°	30°	1	2	3	4	5	6	7	8	9	10	11	12	13	14	15	15	16
15	85	59 •			1.7	1.5	1.6	1.5	D	1	-	-	C	•	•	-	-	H							
20	95	65 •	75	70	2.1	2.2	2.2	2.1	D	1	-	-	C	•	•	-	-	J							
25	110	70 •	80	60	2.9	2.6	2.7	2.6	D	1	-	-	C	•	•	-	-	K							
32	130	80 •	95	65	4.2	3.9	4.0	3.8	D	1	-	-	C	•	•	-	-	L							
40	150	90 •	110	75	4.9	4.5	4.6	4.3	D	1	-	-	C	•	•	-	-	M							
50	120	80	90	65	6.3	5.8	5.9	5.6	D	1	-	-	C	•	•	-	-	N							
65	140	85	100	70	8.1	7.2	7.5	6.9	D	1	-	-	C	•	•	-	-	O							
80	165	100	120	80	10	9.3	9.7	8.9	D	1	-	-	C	•	•	-	-	P							
100	205	115	140	95	13	11	11	10	D	1	-	-	C	•	•	-	-	Q							
125	245	135	170	110	19	15	16	14	D	1	-	-	C	•	•	-	-	R							
150	285	150 •	190	120	25	20	21	18	D	1	-	-	C	•	•	-	-	S							
200	365	190 •	240	145	45	33	37	28	D	1	-	-	C	•	•	-	-	T							
250	450	225 •	285	165	65	46	52	39	D	1	-	-	C	•	•	-	-	U							
300	525	260 •	330	185	89	60	69	50	D	1	-	-	C	•	•	-	-	V							
350	600	290 •	375	210	126	86	120	74	D	1	-	-	C	•	•	-	-	W							
400	680	325 •	425	235	175	119	160	102	D	1	-	-	C	•	•	-	-	X							
450	680	350 •	415	205	179	139	169	125	D	1	-	-	C	•	•	-	-	Y							
500	830*	390 •	795*	275	376	188	230	162	D	1	-	-	C	•	•	-	-	Z							
600	974**	412 •	950**	325	567	292	550	212	D	1	-	-	C	•	•	-	-	B							

\* : 2 parts construction \*\* : 3 parts construction

• : Angle in degree : 90, 45, 60 or 30 • : Assembly not possible with one loose flange

The 30° and 60° elbows are not included in the DIN 2848 standard

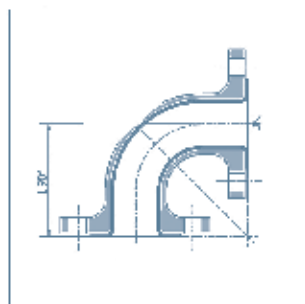

Type K

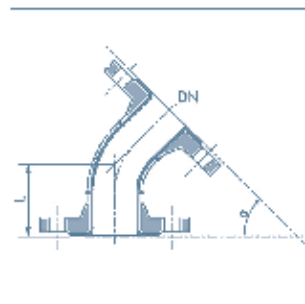

Type W

Standard fixed flanges elbow = 90°/60°/30°

# EQUAL TEES

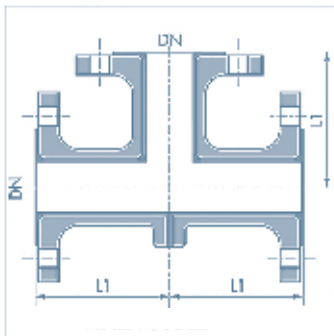

Type K

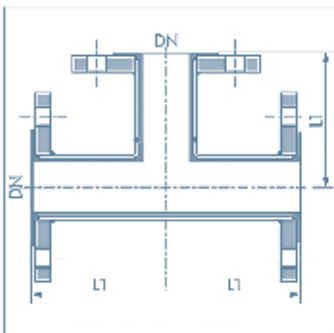

Fixed flanges type P

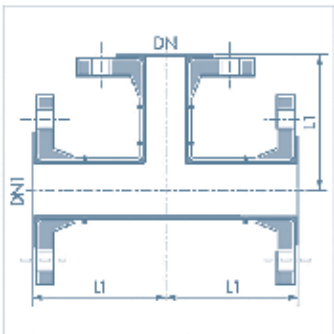

Fixed flanges type W

LINING

- ▶ VIRGIN PFA : DN 15 - DN 80
- ▶ ANTISTATIC PFA : DN 15 - DN 80, C4 = A
- ▶ VIRGIN PTFE : DN 100 - DN 600
- ▶ ANTISTATIC PTFE : DN 100 - DN 400, C4 = A

DN	L1 mm	Weight kg	REFERENCE															
			1	2	3	4	5	6	7	8	9	10	11	12	13	14	15	16
15	85	2.6	D	1	-	-	T	E	-	-	-	H	-	-	-	-	T	
20	95	3.6	D	1	-	-	T	E	-	-	-	J	-	-	-	-	T	
25	110	4.5	D	1	-	-	T	E	-	-	-	K	-	-	-	-	T	
32	130	6.6	D	1	-	-	T	E	-	-	-	L	-	-	-	-	T	
40	150	7.7	D	1	-	-	T	E	-	-	-	M	-	-	-	-	T	
50	120	9.7	D	1	-	-	T	E	-	-	-	N	-	-	-	-	T	
65	140	12	D	1	-	-	T	E	-	-	-	O	-	-	-	-	T	
80	165	16	D	1	-	-	T	E	-	-	-	P	-	-	-	-	T	
100	205	20	D	1	-	-	T	E	-	-	-	Q	-	-	-	-	M	
125	245	30	D	1	-	-	T	E	-	-	-	R	-	-	-	-	M	
150	285	40	D	1	-	-	T	E	-	-	-	S	-	-	-	-	M	
200	365	74	D	1	-	-	T	E	-	-	-	T	-	-	-	-	M	
250*	450	120	D	1	-	-	T	E	-	-	-	U	-	-	-	-	M	
300*	525	162	D	1	-	-	T	E	-	-	-	V	-	-	-	-	M	
350*	600	231	D	1	-	-	T	E	-	-	-	W	-	-	-	-		
400**	680	320	D	1	-	-	T	E	-	-	-	X	-	-	-	-		
450**	680	385	D	1	-	-	T	E	-	-	-	Y	-	-	-	-		
500**	830	473	D	1	-	-	T	E	-	-	-	Z	-	-	-	-		
600**	830	552	D	1	-	-	T	E	-	-	-	B	-	-	-	-		

**Standard construction :**

- Type P : DN 15 to DN 80 and DN 350 to DN 600
- Type K : DN 25 to DN 100, C13 = K
- Type W : DN 100 to DN 300

**On request :**

- 3 loose flanges : C12 = 3

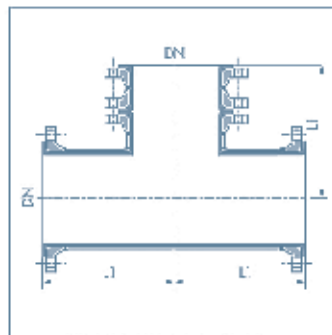

\* Fixed flanges type W

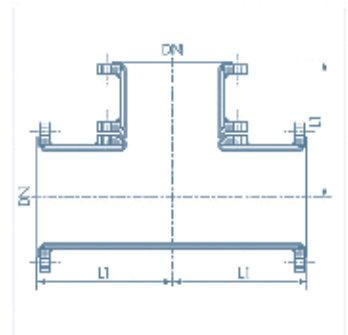

\*\* Fixed flanges type P

# REDUCING TEES



LINING

- ▶ VIRGIN PFA : DN 20 - DN 80
- ▶ ANTISTATIC PFA : DN 20 - DN 80, C4 = A
- ▶ VIRGIN PTFE : DN 100 - DN 125
- ▶ ANTISTATIC PTFE : DN 100 - DN 125, C4 = A

## Standard construction :

- Type K:  
Fixed flanges,  
DN 25 to DN 80  
C13 =K
- Type P :  
Fixed flanges

## On request :

- 3 loose flanges  
C12=3

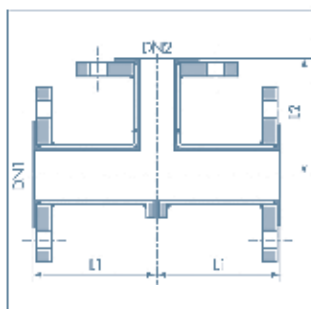

Construction type K

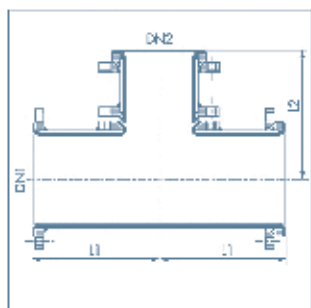

Construction type P

DN1	DN2	L1 mm	L2 mm	Weight kg	REFERENCE															
					1	2	3	4	5	6	7	8	9	10	11	12	13	14	15	16
20	15	95	85	3.2	D	1	-	-	T	R	-	-	-	J	H	-	-	-	T	
	25	110	85	3.8	D	1	-	-	T	R	-	-	-	K	H	-	-	-	T	
25	15	110	85	4.1	D	1	-	-	T	R	-	-	-	K	J	-	-	-	T	
	20	110	95	4.1	D	1	-	-	T	R	-	-	-	K	J	-	-	-	T	
32	15	130	85	5.3	D	1	-	-	T	R	-	-	-	L	H	-	-	-	T	
	20	130	95	5.6	D	1	-	-	T	R	-	-	-	L	J	-	-	-	T	
	25	130	110	5.9	D	1	-	-	T	R	-	-	-	L	K	-	-	-	T	
40	15	150	85	6.0	D	1	-	-	T	R	-	-	-	M	H	-	-	-	T	
	20	150	95	6.4	D	1	-	-	T	R	-	-	-	M	J	-	-	-	T	
	25	150	110	6.7	D	1	-	-	T	R	-	-	-	M	K	-	-	-	T	
	32	150	130	7.4	D	1	-	-	T	R	-	-	-	M	L	-	-	-	T	
50	15	120	85	7.4	D	1	-	-	T	R	-	-	-	N	H	-	-	-	T	
	20	120	95	7.8	D	1	-	-	T	R	-	-	-	N	J	-	-	-	T	
	25	120	110	8.0	D	1	-	-	T	R	-	-	-	N	K	-	-	-	T	
	32	120	130	8.7	D	1	-	-	T	R	-	-	-	N	L	-	-	-	T	
65	40	120	150	9.1	D	1	-	-	T	R	-	-	-	N	M	-	-	-	T	
	25	140	110	9.9	D	1	-	-	T	R	-	-	-	O	K	-	-	-	T	
	32	140	130	10	D	1	-	-	T	R	-	-	-	O	L	-	-	-	T	
	40	140	150	11	D	1	-	-	T	R	-	-	-	O	M	-	-	-	T	
80	50	140	120	11	D	1	-	-	T	R	-	-	-	O	N	-	-	-	T	
	25	165	110	12	D	1	-	-	T	R	-	-	-	P	K	-	-	-	T	
	32	165	130	13	D	1	-	-	T	R	-	-	-	P	L	-	-	-	T	
	40	165	150	13	D	1	-	-	T	R	-	-	-	P	M	-	-	-	T	
100	50	165	120	14	D	1	-	-	T	R	-	-	-	P	N	-	-	-	T	
	65	165	140	15	D	1	-	-	T	R	-	-	-	P	O	-	-	-	T	
	40	205	150	16	D	1	-	-	T	R	-	-	-	Q	M	-	-	-	M	
	50	205	120	17	D	1	-	-	T	R	-	-	-	Q	N	-	-	-	M	
125	65	205	140	18	D	1	-	-	T	R	-	-	-	Q	O	-	-	-	M	
	80	205	165	19	D	1	-	-	T	R	-	-	-	Q	P	-	-	-	M	
	40	245	150	23	D	1	-	-	T	R	-	-	-	R	M	-	-	-	M	
	50	245	120	23	D	1	-	-	T	R	-	-	-	R	N	-	-	-	M	
125	65	245	140	24	D	1	-	-	T	R	-	-	-	R	O	-	-	-	M	
	80	245	165	25	D	1	-	-	T	R	-	-	-	R	P	-	-	-	M	
	100	245	205	27	D	1	-	-	T	R	-	-	-	R	Q	-	-	-	M	

# REDUCING TEES

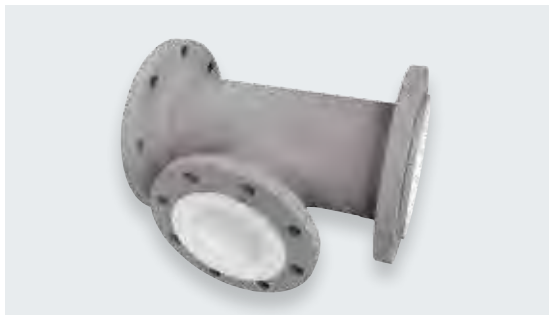

LINING

- ▶ VIRGIN PTFE : DN 150 – DN 600
- ▶ ANTISTATIC PTFE, C4 = A : DN 150 – DN 400

## Standard construction :

- Type P : fixed flanges
- Type W : fixed flanges

## On request :

- Loose flange : C12 = 3

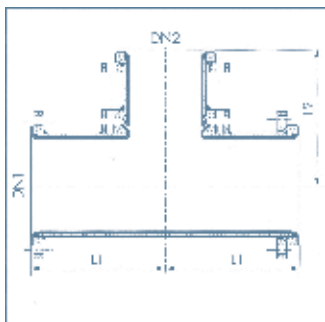

Type P

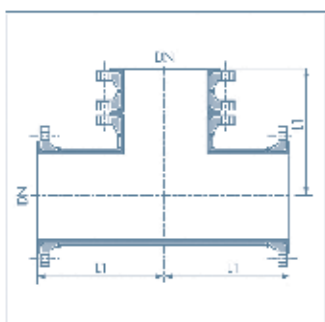

Type W

DN1	DN2	L1 mm	L2 mm	Weight kg	REFERENCE															
					1	2	3	4	5	6	7	8	9	10	11	12	13	14	15	16
150	40	285	150	30	D	1	-	-	T	R	-	-	-	S	M	-	-	-	M	
	50	285	120	31	D	1	-	-	T	R	-	-	-	S	N	-	-	-	M	
	65	285	140	32	D	1	-	-	T	R	-	-	-	S	O	-	-	-	M	
	80	285	165	33	D	1	-	-	T	R	-	-	-	S	P	-	-	-	M	
	100	285	205	34	D	1	-	-	T	R	-	-	-	S	Q	-	-	-	M	
	125	285	245	37	D	1	-	-	T	R	-	-	-	S	R	-	-	-	M	
200	80	365	165	57	D	1	-	-	T	R	-	-	-	T	P	-	-	-	M	
	100	365	205	58	D	1	-	-	T	R	-	-	-	T	Q	-	-	-	M	
	125	365	245	60	D	1	-	-	T	R	-	-	-	T	R	-	-	-	M	
	150	365	285	64	D	1	-	-	T	R	-	-	-	T	S	-	-	-	M	
250	100	450	205	81	D	1	-	-	T	R	-	-	-	U	Q	-	-	-	M	
	125	450	245	84	D	1	-	-	T	R	-	-	-	U	R	-	-	-	M	
	150	450	285	87	D	1	-	-	T	R	-	-	-	U	S	-	-	-	M	
	200	450	365	96	D	1	-	-	T	R	-	-	-	U	V	-	-	-	M	
300	100	525	205	113	D	1	-	-	T	R	-	-	-	V	Q	-	-	-	M	
	150	525	285	116	D	1	-	-	T	R	-	-	-	V	S	-	-	-	M	
	200	525	365	125	D	1	-	-	T	R	-	-	-	V	V	-	-	-	M	
	250*	525	450	148	D	1	-	-	T	R	-	-	-	V	U					
350	100	600	205	156	D	1	-	-	T	R	-	-	-	W	Q					
	150	600	285	159	D	1	-	-	T	R	-	-	-	W	S					
	200*	600	365	178	D	1	-	-	T	R	-	-	-	W	V					
	250*	600	450	191	D	1	-	-	T	R	-	-	-	W	U					
	300*	600	525	205	D	1	-	-	T	R	-	-	-	W	V					
400*	200	680	365	234	D	1	-	-	T	R	-	-	-	X	V					
	250	600	450	247	D	1	-	-	T	R	-	-	-	X	U					
	300	680	525	261	D	1	-	-	T	R	-	-	-	X	V					
	350	680	600	287	D	1	-	-	T	R	-	-	-	X	X					
450*	300	680	525	324	D	1	-	-	T	R	-	-	-	Y	V					
	350	680	600	357	D	1	-	-	T	R	-	-	-	Y	W					
500*	200	830	365	258	D	1	-	-	T	R	-	-	-	Z	V					
	250	830	450	270	D	1	-	-	T	R	-	-	-	Z	U					
	300	830	525	282	D	1	-	-	T	R	-	-	-	Z	V					
	350	830	600	308	D	1	-	-	T	R	-	-	-	Z	W					
	400	830	680	340	D	1	-	-	T	R	-	-	-	Z	X					
600*	450	830	680	368	D	1	-	-	T	R	-	-	-	Z	Y					
	250	830	450	412	D	1	-	-	T	R	-	-	-	B	U					
	300	830	525	425	D	1	-	-	T	R	-	-	-	B	V					
	350	830	600	440	D	1	-	-	T	R	-	-	-	B	W					
	400	830	680	465	D	1	-	-	T	R	-	-	-	B	X					
	450	830	830	495	D	1	-	-	T	R	-	-	-	B	Y					
	500	830	830	525	D	1	-	-	T	R	-	-	-	B	Z					

\* 2 parts construction



# REDUCING FLANGES



LINING

▶ VIRGIN PTFE : DN 20 - DN 80

▶ ANTISTATIC PTFE, C4 = A : DN 20 - DN 80

DN1	DN2	ØD mm	b mm	DN1			DN2			Type	Weight kg	REFERENCE																								
				Ø k1 mm	Holes			Ø k2 mm	Holes			1	2	3	4	5	6	7	8	9	10	11	12	13	14	15	16									
					ks	Ø	Bolting		nb																			Bolting								
20	15	105	35	75	4 x		M12	65	4 x	M12	C	1.9	D	1	-	-	B	R	-	-	-	J	H													
	25	115	35	85	4 x		M12	65	4 x	M12	C	2.1	D	1	-	-	B	R	-	-	-	K	H													
25	20	115	35	85	4 x		M12	75	4 x	M12	C	2.0	D	1	-	-	B	R	-	-	-	K	J													
	32	140	35	100	4 x		M16	65	4 x	M12	C	3.3	D	1	-	-	B	R	-	-	-	L	H													
32	20	140	35	100	4 x		M16	75	4 x	M12	C	3.2	D	1	-	-	B	R	-	-	-	L	J													
	25	140	35	100	4 x		M16	85	4 x	M12	C	3.1	D	1	-	-	B	R	-	-	-	L	K													
	40	150	35	110	4 x		M16	65	4 x	M12	B	4.1	D	1	-	-	B	R	-	-	-	M	H													
40	20	150	35	110	4 x		M16	75	4 x	M12	B	4.0	D	1	-	-	B	R	-	-	-	M	J													
	25	150	35	110	4 x		M16	85	4 x	M12	C	3.9	D	1	-	-	B	R	-	-	-	M	K													
	32	150	35	110	4 x		M16	100	4 x	M16	C	3.8	D	1	-	-	B	R	-	-	-	M	L													
50	15	165	35	125	4 x		M16	65	4 x	M12	B	4.8	D	1	-	-	B	R	-	-	-	N	H													
	20	165	35	125	4 x		M16	75	4 x	M12	B	4.8	D	1	-	-	B	R	-	-	-	N	J													
	25	165	35	125	4 x		M16	85	4 x	M12	B	4.7	D	1	-	-	B	R	-	-	-	N	K													
	32	165	35	125	4 x		M16	100	4 x	M12	C	4.6	D	1	-	-	B	R	-	-	-	N	L													
50	40	165	35	125	4 x		M16	110	4 x	M16	C	4.5	D	1	-	-	B	R	-	-	-	N	M													
	20	185	35	145	4 x		M16	75	8 x	M12	B	5.8	D	1	-	-	B	R	-	-	-	O	J													
	25	185	35	145	4 x		M16	85	8 x	M12	B	5.7	D	1	-	-	B	R	-	-	-	O	K													
65	32	185	35	145	4 x		M16	100	8 x	M16	B	5.6	D	1	-	-	B	R	-	-	-	O	L													
	40	185	35	145	4 x		M16	110	8 x	M16	C	5.4	D	1	-	-	B	R	-	-	-	O	M													
	50	185	35	145	4 x		M16	125	8 x	M16	C	5.3	D	1	-	-	B	R	-	-	-	O	N													
80	15	200	35	160	8 x	18		65	4 x	M12	A	6.7	D	1	-	-	B	R	-	-	-	P	H													
	20	200	35	160	8 x	18		75	4 x	M12	A	6.6	D	1	-	-	B	R	-	-	-	P	J													
	25	200	35	160	8 x	18		85	4 x	M12	A	6.5	D	1	-	-	B	R	-	-	-	P	K													
	32	200	35	160	8 x		M16	100	4 x	M16	B	6.4	D	1	-	-	B	R	-	-	-	P	L													
	40	200	35	160	8 x		M16	110	4 x	M16	B	6.2	D	1	-	-	B	R	-	-	-	P	M													
	50	200	35	160	8 x		M16	125	4 x	M16	B	6.0	D	1	-	-	B	R	-	-	-	P	N													
65	200	35	160	8 x		M16	145	8 x	M16	B	5.7	D	1	-	-	B	R	-	-	-	P	O														

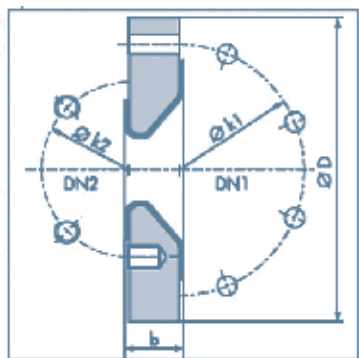

Tapped hole / through hole type A

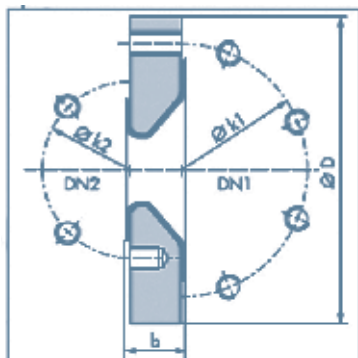

Tapped hole type B

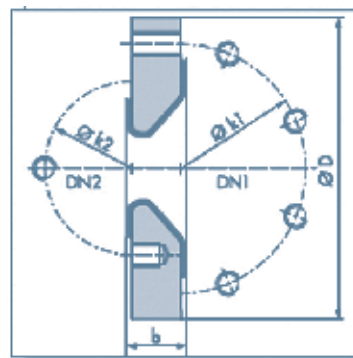

Tapped holes on center-line / off center-line type C





**LINING**

- ▶ VIRGIN PTFE : DN 100 - DN 250
- ▶ ANTISTATIC PTFE, C4 = A : DN 100 - DN 250

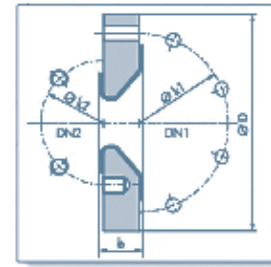

Tapped hole /  
through hole  
Type A

DN1	DN2	ØD mm	b mm	DN1			DN2			Type	Weight kg	REFERENCE																			
				Ø k1 mm	Holes		Ø k2 mm	Holes				1	2	3	4	5	6	7	8	9	10	11	12	13	14	15	16				
					nb	Ø		Bolting	nb																			Bolting			
100	15	228	45	180	8 x	18		65	4 x	M12	A	11	D	1	-	-	B	R	-	-	-	Q	H								
	20	228	45	180	8 x	18		75	4 x	M12	A	11	D	1	-	-	B	R	-	-	-	Q	J								
	25	228	45	180	8 x	18		85	4 x	M12	A	11	D	1	-	-	B	R	-	-	-	Q	K								
	32	228	45	180	8 x	18		100	4 x	M16	A	11	D	1	-	-	B	R	-	-	-	Q	L								
	40	228	45	180	8 x	18		110	4 x	M16	A	11	D	1	-	-	B	R	-	-	-	Q	M								
	50	228	45	180	8 x		M16	125	4 x	M16	B	10	D	1	-	-	B	R	-	-	-	Q	N								
	65	228	45	180	8 x		M16	145	8 x	M16	B	10	D	1	-	-	B	R	-	-	-	Q	O								
	80	228	45	180	8 x		M16	160	8 x	M12	C	10	D	1	-	-	B	R	-	-	-	Q	P								
125	32	254	45	210	8 x	18		100	4 x	M16	A	13	D	1	-	-	B	R	-	-	-	R	L								
	40	254	45	210	8 x	18		110	4 x	M16	A	13	D	1	-	-	B	R	-	-	-	R	M								
	50	254	45	210	8 x	18		125	4 x	M16	A	12	D	1	-	-	B	R	-	-	-	R	N								
	65	254	45	210	8 x		M16	145	8 x	M16	B	12	D	1	-	-	B	R	-	-	-	R	O								
	80	254	45	210	8 x		M16	160	8 x	M16	B	12	D	1	-	-	B	R	-	-	-	R	P								
	100	254	45	210	8 x		M16	180	8 x	M16	C	12	D	1	-	-	B	R	-	-	-	R	Q								
150	25	285	45	240	8 x	22		85	4 x	M12		17	D	1	-	-	B	R	-	-	-	S	K								
	32	285	45	240	8 x	22		100	4 x	M16	A	17	D	1	-	-	B	R	-	-	-	S	L								
	40	285	45	240	8 x	22		110	4 x	M16	A	17	D	1	-	-	B	R	-	-	-	S	M								
	50	285	45	240	8 x	22		125	4 x	M16	A	17	D	1	-	-	B	R	-	-	-	S	N								
	65	285	45	240	8 x	22		145	8 x	M16	A	17	D	1	-	-	B	R	-	-	-	S	O								
	80	285	45	240	8 x	22		160	8 x	M16	A	16	D	1	-	-	B	R	-	-	-	S	P								
	100	285	45	240	8 x		M20	180	8 x	M16	B	15	D	1	-	-	B	R	-	-	-	S	Q								
	125	285	45	240	8 x		M20	210	8 x	M20	B	14	D	1	-	-	B	R	-	-	-	S	R								
200	25	343	45	295	8 x	22		85	4 x	M12	C	25	D	1	-	-	B	R	-	-	-	T	K								
	32	343	45	295	8 x	22		100	4 x	M16	A	25	D	1	-	-	B	R	-	-	-	T	L								
	40	343	45	295	8 x	22		110	4 x	M16	A	25	D	1	-	-	B	R	-	-	-	T	M								
	50	343	45	295	8 x	22		125	4 x	M16	A	25	D	1	-	-	B	R	-	-	-	T	N								
	65	343	45	295	8 x	22		145	8 x	M16	A	25	D	1	-	-	B	R	-	-	-	T	O								
	80	343	45	295	8 x	22		160	8 x	M16	A	24	D	1	-	-	B	R	-	-	-	T	P								
	100	343	45	295	8 x	22		180	8 x	M16	A	23	D	1	-	-	B	R	-	-	-	T	Q								
	125	343	45	295	8 x	22		210	8 x	M20	B	22	D	1	-	-	B	R	-	-	-	T	R								
	150	343	45	295	8 x		M20	240	8 x	M20	B	20	D	1	-	-	B	R	-	-	-	T	S								
250	40	406	45	350	12 x	22		110	4 x	M16	A	34	D	1	-	-	B	R	-	-	-	U	M								
	50	406	45	350	12 x	22		125	4 x	M16	A	34	D	1	-	-	B	R	-	-	-	U	N								
	65	406	45	350	12 x	22		145	8 x	M16	A	34	D	1	-	-	B	R	-	-	-	U	O								
	80	406	45	350	12 x	22		160	8 x	M16	A	33	D	1	-	-	B	R	-	-	-	U	P								



# INSTRUMENT TEES



## LINING

- ▶ **VIRGIN PFA :**  
DN 15 - DN 200
- ▶ **ANTISTATIC PFA,**  
C4 = A : DN 15 - DN 200
- ▶ **VIRGIN PTFE :**  
DN 250 - DN 600
- ▶ **ANTISTATIC PTFE,**  
C4 = A : DN 250 - DN 400

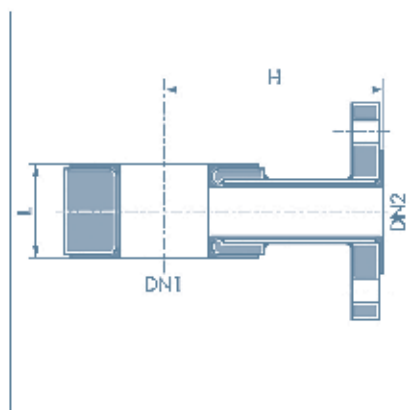

Fixed flanges

DN1	DN2	L mm	H mm	Weight kg	REFERENCE																
					1	2	3	4	5	6	7	8	9	10	11	12	13	14	15	16	
25	15	50	90	1.9	D	1	-	-	P	I	-	-	-	K	H						
	20	50	90	1.9	D	1	-	-	P	I	-	-	-	K	J						
	25	50	90	2.0	D	1	-	-	P	I	-	-	-	K	K						
32	15	50	100	2.6	D	1	-	-	P	I	-	-	-	L	H						
	20	50	100	2.7	D	1	-	-	P	I	-	-	-	L	J						
	25	50	100	2.8	D	1	-	-	P	I	-	-	-	L	K						
40	15	50	110	2.7	D	1	-	-	P	I	-	-	-	M	H						
	20	50	110	2.8	D	1	-	-	P	I	-	-	-	M	J						
	25	50	110	3.0	D	1	-	-	P	I	-	-	-	M	K						
	40	75	110	4.6	D	1	-	-	P	I	-	-	-	M	M						
50	15	50	115	4.7	D	1	-	-	P	I	-	-	-	N	H						
	20	50	115	4.8	D	1	-	-	P	I	-	-	-	N	J						
	25	50	115	5.0	D	1	-	-	P	I	-	-	-	N	K						
	40	75	115	8.4	D	1	-	-	P	I	-	-	-	N	M						
	50	90	115	9.9	D	1	-	-	P	I	-	-	-	N	N						
65	15	50	125	5.0	D	1	-	-	P	I	-	-	-	O	H						
	20	50	125	5.1	D	1	-	-	P	I	-	-	-	O	J						
	25	50	125	5.5	D	1	-	-	P	I	-	-	-	O	K						
	40	75	125	9.2	D	1	-	-	P	I	-	-	-	O	M						
80	50	90	125	11	D	1	-	-	P	I	-	-	-	O	N						
	15	50	135	5.7	D	1	-	-	P	I	-	-	-	P	H						
	20	50	135	5.8	D	1	-	-	P	I	-	-	-	P	J						
	25	50	135	6.0	D	1	-	-	P	I	-	-	-	P	K						
	40*	75	135	11	D	1	-	-	P	I	-	-	-	P	M						
100	50*	90	135	12	D	1	-	-	P	I	-	-	-	P	N						
	15	50	150	6.7	D	1	-	-	P	I	-	-	-	Q	H						
	20	50	150	6.8	D	1	-	-	P	I	-	-	-	Q	J						
	25	50	150	7.0	D	1	-	-	P	I	-	-	-	Q	K						
125	40*	75	150	12	D	1	-	-	P	I	-	-	-	Q	M						
	50*	90	150	13	D	1	-	-	P	I	-	-	-	Q	N						
	25	50	160	8.6	D	1	-	-	P	I	-	-	-	R	K						
	40	75	160	13	D	1	-	-	P	I	-	-	-	R	M						
150	50	90	160	21	D	1	-	-	P	I	-	-	-	R	N						
	15	50	180	8.9	D	1	-	-	P	I	-	-	-	S	H						
	20	50	180	9.0	D	1	-	-	P	I	-	-	-	S	J						
	25	50	180	10	D	1	-	-	P	I	-	-	-	S	K						
200	40	75	180	15	D	1	-	-	P	I	-	-	-	S	M						
	50	90	180	16	D	1	-	-	P	I	-	-	-	S	N						
	15	50	210	10	D	1	-	-	P	I	-	-	-	T	H						
	20	50	210	10	D	1	-	-	P	I	-	-	-	T	J						
	25	50	210	10	D	1	-	-	P	I	-	-	-	T	K						
250	40	75	210	16	D	1	-	-	P	I	-	-	-	T	M						
	50	90	210	17	D	1	-	-	P	I	-	-	-	T	N						
	25	50	240	24	D	1	-	-	P	I	-	-	-	U	K						
	40	75	240	26	D	1	-	-	P	I	-	-	-	U	M						
	50	90	240	27	D	1	-	-	P	I	-	-	-	U	N						
300	25	50	340	26	D	1	-	-	P	I	-	-	-	V	K						
	40	75	340	29	D	1	-	-	P	I	-	-	-	V	M						
	50	90	340	30	D	1	-	-	P	I	-	-	-	V	N						
350	25	50	375	41	D	1	-	-	P	I	-	-	-	W	K						
	40	75	375	44	D	1	-	-	P	I	-	-	-	W	M						
	50	90	375	45	D	1	-	-	P	I	-	-	-	W	N						
400	25	90	390	46	D	1	-	-	P	I	-	-	-	X	K						
	40	110	390	48	D	1	-	-	P	I	-	-	-	X	M						
	50	120	390	50	D	1	-	-	P	I	-	-	-	X	N						
450	25	90	419	51	D	1	-	-	P	I	-	-	-	Y	K						
	40	110	419	54	D	1	-	-	P	I	-	-	-	Y	M						
	50	120	419	55	D	1	-	-	P	I	-	-	-	Y	N						
500	25**	90	450	60	D	1	-	-	P	I	-	-	-	Z	K						
	40**	110	450	63	D	1	-	-	P	I	-	-	-	Z	M						
	50**	120	450	64	D	1	-	-	P	I	-	-	-	Z	N						
600	25**	90	559	69	D	1	-	-	P	I	-	-	-	Z	K						
	40**	110	559	72	D	1	-	-	P	I	-	-	-	Z	M						
	50**	120	559	73	D	1	-	-	P	I	-	-	-	B	N						

\* Assembly only possible using 4 bolts \*\* In 2 parts

# CROSSES



LINING

- ▶ VIRGIN PFA : DN 15 - DN 80
- ▶ ANTISTATIC PFA : DN 15 - DN 80
- ▶ VIRGIN PTFE : DN 100 - DN 600
- ▶ ANTISTATIC PTFE : DN 100 - DN 400

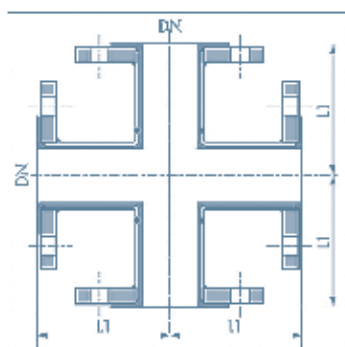

Fixed flanges  
type P

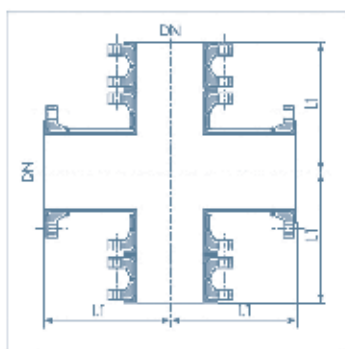

\* Fixed flanges  
type W

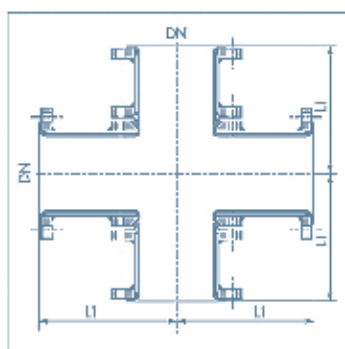

\*\* Fixed flanges  
type P

DN	L1 mm	Weight kg	REFERENCE															
			1	2	3	4	5	6	7	8	9	10	11	12	13	14	15	16
15	85	3.4	D	1	-	-	X	E	-	-	-	H						
20	95	4.7	D	1	-	-	X	E	-	-	-	J						
25	110	5.9	D	1	-	-	X	E	-	-	-	K						
32	130	8.8	D	1	-	-	X	E	-	-	-	L						
40	150	10	D	1	-	-	X	E	-	-	-	M						
50	120	12	D	1	-	-	X	E	-	-	-	N						
65	140	16	D	1	-	-	X	E	-	-	-	O						
80	165	21	D	1	-	-	X	E	-	-	-	P						
100	205	27	D	1	-	-	X	E	-	-	-	Q						
125	245	39	D	1	-	-	X	E	-	-	-	R						
150	285	53	D	1	-	-	X	E	-	-	-	S						
200	365	116	D	1	-	-	X	E	-	-	-	T						
250*	450	165	D	1	-	-	X	E	-	-	-	U						
300*	525	219	D	1	-	-	X	E	-	-	-	V						
350*	600	315	D	1	-	-	X	E	-	-	-	W						
400*	680	435	D	1	-	-	X	E	-	-	-	X						
450**	680	525	D	1	-	-	X	E	-	-	-	Y						
500**	830	590	D	1	-	-	X	E	-	-	-	Z						
600**	830	720	D	1	-	-	X	E	-	-	-	B						

**Standard construction :**

- Type P : DN 15 to DN 80 and DN 450 to DN 600
- Type W : DN 100 to DN 400

**On request :**

- 4 loose flanges : C12 = 4



# SPACERS



LINING

- ▶ VIRGIN PTFE : DN 15 - DN 600
- ▶ ANTISTATIC PTFE, C4 = A : DN 15 - DN 400

DN	ØA	F (mm)	G (mm)		H (mm)		REFERENCE															
			L min.	L max.	L min.	L max.	1	2	3	4	5	6	7	8	9	10	11	12	13	14	15	16
15	51	20	15	50	50	85	D	1	-	-	•	-	x	x	x	H						
20	60	20	15	50	50	85	D	1	-	-	•	-	x	x	x	J						
25	70	20	15	50	50	85	D	1	-	-	•	-	x	x	x	K						
32	82	20	15	60	60	85	D	1	-	-	•	-	x	x	x	L						
40	92	20	15	60	60	90	D	1	-	-	•	-	x	x	x	M						
50	107	20	15	60	60	100	D	1	-	-	•	-	x	x	x	N						
65	127	20	15	60	60	100	D	1	-	-	•	-	x	x	x	O						
80	142	20	15	60	60	110	D	1	-	-	•	-	x	x	x	P						
100	162	20	15	60	60	113	D	1	-	-	•	-	x	x	x	Q						
125	192	20	15	60	60	117	D	1	-	-	•	-	x	x	x	R						
150	218	20	20	60	60	117	D	1	-	-	•	-	x	x	x	S						
200	273	20	20	70	70	130	D	1	-	-	•	-	x	x	x	T						
250	328	20	20	70	70	143	D	1	-	-	•	-	x	x	x	U						
300	378	20	20	70	70	143	D	1	-	-	•	-	x	x	x	V						
350	438	20	20	70	70	143	D	1	-	-	•	-	x	x	x	W						
400	488	20	20	80	80	147	D	1	-	-	•	-	x	x	x	X						
450	539	20	20	80	80	147	D	1	-	-	•	-	x	x	x	Y						
500	594	20	20	80	80	156	D	1	-	-	•	-	x	x	x	Z						
600	695	20	20	80	80	172	D	1	-	-	•	-	x	x	x	B						

• = F : Spacers shape F    • = G : Spacers shape G    • = E : Spacers shape H    xxxx : length in mm

Massive PTFE spacer

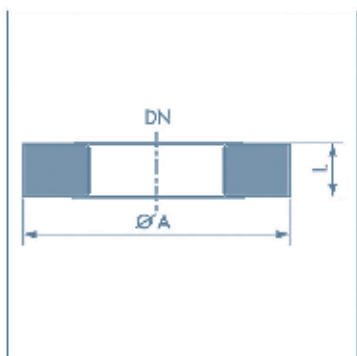

Shape F

Steel lined spacer

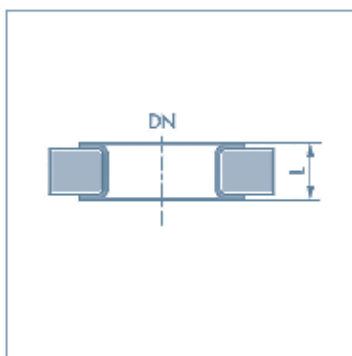

Shape G

Tube lined spacer

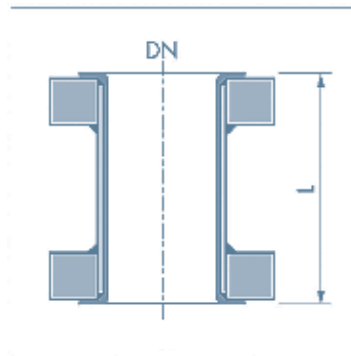

Shape H

Mersen also supplies inclined spacers type F

# SPECTACLE BLINDS

## LINING

- ▶ VIRGIN PTFE : DN 20 - DN 600
- ▶ ANTISTATIC PTFE, C4 = A : DN 20 - DN 400

DN	ØD	C	E	ØA	b	Weight	REFERENCE															
							1	2	3	4	5	6	7	8	9	10	11	12	13	14	15	16
20	61	75	35	16	14	1.9	D	1	-	-	O	B	-	-	-	J						
25	71	85	40	16	14	2.6	D	1	-	-	O	B	-	-	-	K						
32	82	100	50	19	14	3.9	D	1	-	-	O	B	-	-	-	L						
40	92	110	55	19	14	4.4	D	1	-	-	O	B	-	-	-	M						
50	107	125	65	19	14	5.9	D	1	-	-	O	B	-	-	-	N						
65	127	145	70	19	14	7.4	D	1	-	-	O	B	-	-	-	O						
80	142	160	40	19	14	8.5	D	1	-	-	O	B	-	-	-	P						
100	162	180	50	19	18	9.8	D	1	-	-	O	B	-	-	-	Q						
125	192	210	60	19	18	14	D	1	-	-	O	B	-	-	-	R						
150	218	240	65	24	18	19	D	1	-	-	O	B	-	-	-	S						
200	273	295	80	24	21	28	D	1	-	-	O	B	-	-	-	T						
250	328	350	65	24	23	39	D	1	-	-	O	B	-	-	-	U						
300	378	400	80	24	26	48	D	1	-	-	O	B	-	-	-	V						
350	438	460	65	24	28	64	D	1	-	-	O	B	-	-	-	W						
400	488	515	70	28	30	79	D	1	-	-	O	B	-	-	-	X						
450	538	565	60	28	30	94	D	1	-	-	O	B	-	-	-	Y						
500	593	620	70	28	33	123	D	1	-	-	O	B	-	-	-	Z						
600	695	725	80	32	38	191	D	1	-	-	O	B	-	-	-	B						

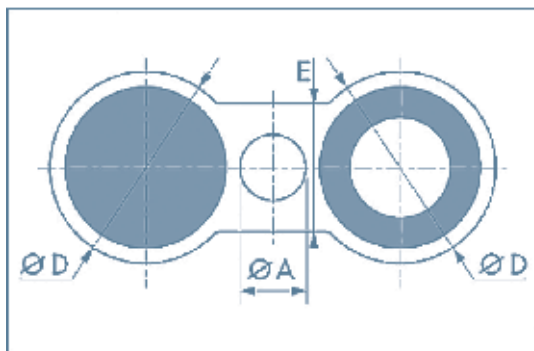

Spectacle blind (front view)

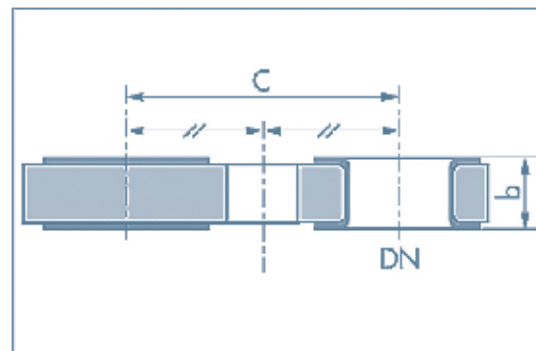

Spectacle blind (sectional view)

# BLIND FLANGES & LATERAL TEES

## BLIND FLANGES



### LINING

- ▶ VIRGIN PTFE :  
DN 15 - DN 600
- ▶ PTFE ANTISTATIC,  
C4 = A :  
DN 15 - DN 400

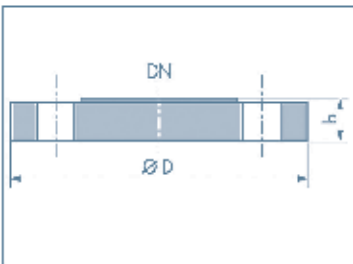

DN	ØD	b	Weight kg	REFERENCE															
	mm	mm		1	2	3	4	5	6	7	8	9	10	11	12	13	14	15	16
15	95	18	0.7	D	1	-	-	B	P	-	-	-	H						
20	105	20	1.0	D	1	-	-	B	P	-	-	-	J						
25	115	20	1.2	D	1	-	-	B	P	-	-	-	K						
32	140	20	1.3	D	1	-	-	B	P	-	-	-	L						
40	150	20	2.1	D	1	-	-	B	P	-	-	-	M						
50	165	22	2.9	D	1	-	-	B	P	-	-	-	N						
65	185	22	3.7	D	1	-	-	B	P	-	-	-	O						
80	200	24	4.9	D	1	-	-	B	P	-	-	-	P						
100	220	24	5.8	D	1	-	-	B	P	-	-	-	Q						
125	250	26	8.6	D	1	-	-	B	P	-	-	-	R						
150	285	26	10	D	1	-	-	B	P	-	-	-	S						
200	340	28	16	D	1	-	-	B	P	-	-	-	T						
250	395	30	24	D	1	-	-	B	P	-	-	-	U						
300	445	30	31	D	1	-	-	B	P	-	-	-	V						
350	505	30	41	D	1	-	-	B	P	-	-	-	W						
400	565	30	50	D	1	-	-	B	P	-	-	-	X						
450	615	30	65	D	1	-	-	B	P	-	-	-	Y						
500	670	31	76	D	1	-	-	B	P	-	-	-	Z						
600	780	36	132	D	1	-	-	B	P	-	-	-	B						

## LATERAL TEES

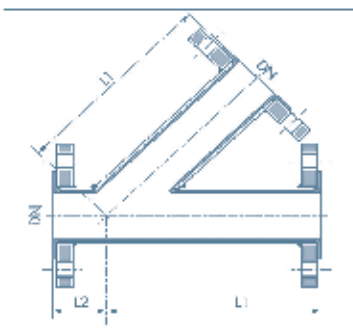

Lateral tees type P



DN	L1	L2	Weight kg	REFERENCE															
	mm	mm		1	2	3	4	5	6	7	8	9	10	11	12	13	14	15	16
25	146	44	6.0	D	1	-	-	T	L	-	-	-	K						
32	180	44	8.0	D	1	-	-	T	L	-	-	-	L						
40	178	51	10	D	1	-	-	T	L	-	-	-	M						
50	203	63	12	D	1	-	-	T	L	-	-	-	N						
65	241	64	17	D	1	-	-	T	L	-	-	-	O						
80	254	76	21	D	1	-	-	T	L	-	-	-	P						
100	305	76	33	D	1	-	-	T	L	-	-	-	Q						
125	343	89	28	D	1	-	-	T	L	-	-	-	R						
150	368	89	49	D	1	-	-	T	L	-	-	-	S						
200	445	114	70	D	1	-	-	T	L	-	-	-	T						

### LINING

- ▶ VIRGIN PFA : DN 25 & DN 40 - 100
- ▶ ANTISTATIC PFA, C4 = A : DN 25 - DN 100
- ▶ VIRGIN PTFE : DN 32, DN 65 & DN 125 - 200
- ▶ ANTISTATIC PTFE, C4 = A : DN 125 - DN 200



# MANIFOLDS



## LINING

- ▶ **VIRGIN PTFE :**  
DN 25 - DN 300
- ▶ **ANTISTATIC PTFE :**  
DN 25 - DN 300

**DRAWING ABOVE IS SHOWN  
AS AN EXAMPLE**

**Other manifolds configurations  
on request :** number, DN  
and nozzles inclination  
**L maxi : 1,5 meter**

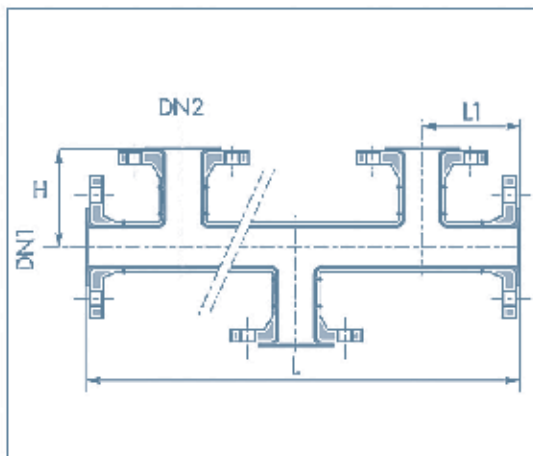

Fixed flanges manifolds type W

DN1	DN2	H	L1
		mm	mm
25	25	110	110
	32	130	130
40	25	110	110
	32	130	130
	40	150	150
50	25	110	110
	32	130	130
	40	150	150
	50	120	120
65	25	110	110
	32	130	130
	40	150	150
	50	120	120
	65	140	140
80	25	110	110
	32	130	130
	40	150	150
	50	120	120
	65	140	140
	80	165	165
100	25	110	110
	32	130	130
	40	150	150
	50	120	120
	65	140	140
	80	165	165
	100	205	205
	125	245	245
125	25	130	100
	32	130	130
	40	150	150
	50	150	120
	65	140	140
	80	165	165
	100	205	205
	125	245	245
	150	285	285
	200	365	365

DN1	DN2	H	L1
		mm	mm
150	25	130	110
	32	150	130
	40	150	150
	50	150	120
	65	150	140
	80	165	165
	100	205	205
200	125	245	245
	150	285	285
	32	180	130
	40	200	150
	50	200	120
	65	200	140
	80	205	165
	100	205	205
	125	245	245
	150	285	285
250	200	365	365
	40	220	150
	50	220	120
	65	220	140
	80	220	165
	100	245	205
	125	245	245
	150	285	285
	200	305	365
	250	305	450
300	250	305	450
	65	245	140
	80	245	165
	100	245	205
	125	245	245
	150	285	285
	200	305	365
	250	305	450
	300	305	525

# DOUBLE JACKETED PIPING

## STRAIGHT LENGTHS

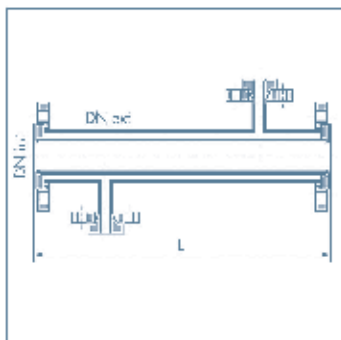

LINING

- ▶ VIRGIN PTFE :  
DN 20 - DN 100
- ▶ ANTISTATIC PTFE C4 = A :  
DN 20 - DN 100

DN int	DN ext	L min. mm	L max. mm
20	32	200	6000
25	40	200	6000
32	50	200	6000
40	65	200	6000
50	80	200	6000
65	100	200	6000
80	100	200	6000
100	125	200	6000

## 90° ELBOWS & EQUAL TEES

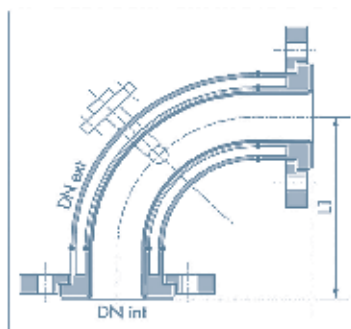

90° elbows

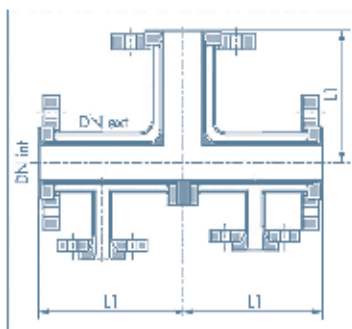

Equal tees

The jacketed pipe connections are made through nozzle DN 20.

Other connection types are possible on request.

**Other dimensions and part type on request.**

DN int	DN ext	L1 mm
25	40	110
32	50	130
40	65	150
50	80	120
65	100	140
80	100	165
100	125	205

# DIP PIPES & ENTRY PIPES

## ENTRY PIPES

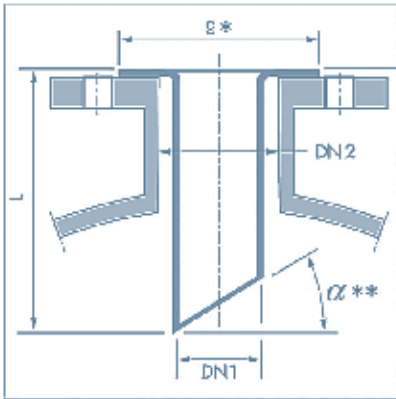

Type A

### LINING

- ▶ **VIRGIN PTFE :**  
DN 15 - DN 500
- ▶ **ANTISTATIC PTFE, C4 = A :**  
DN 15 - DN 400

DN1	DN2 min.	L max. mm	REFERENCE															
			1	2	3	4	5	6	7	8	9	10	11	12	13	14	15	16
20	25	3000	D	1	-	-	N	x	x	x	x	J						
25	32	3000	D	1	-	-	N	x	x	x	x	K						
32	40	3000	D	1	-	-	N	x	x	x	x	L						
40	50	3000	D	1	-	-	N	x	x	x	x	M						
50	65	3000	D	1	-	-	N	x	x	x	x	N						
65	80	3000	D	1	-	-	N	x	x	x	x	O						
80	100	3000	D	1	-	-	N	x	x	x	x	P						
100	125	3000	D	1	-	-	N	x	x	x	x	Q						
125	150	3000	D	1	-	-	N	x	x	x	x	R						
150	200	3000	D	1	-	-	N	x	x	x	x	S						
200	250	3000	D	1	-	-	N	x	x	x	x	T						
250	300	3000	D	1	-	-	N	x	x	x	x	U						
300	350	3000	D	1	-	-	N	x	x	x	x	V						
350	400	3000	D	1	-	-	N	x	x	x	x	W						
400	450	2000	D	1	-	-	N	x	x	x	x	X						
450	500	2000	D	1	-	-	N	x	x	x	x	Y						
500	600	1500	D	1	-	-	N	x	x	x	x	Z						

\* Collar G diameter in accordance with DN2 \*\*  $\alpha$  : other angles are possible on request.

xxxx : length in mm

## DIP PIPES

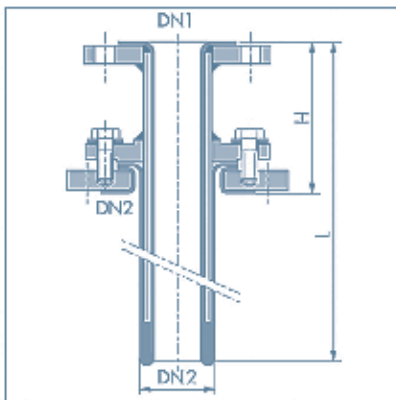

Type B

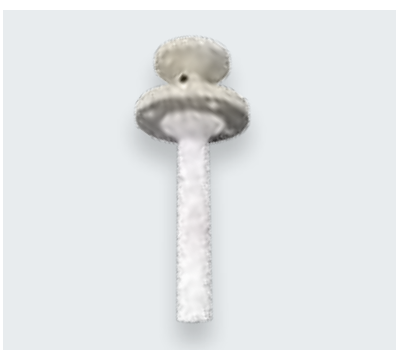

DN1		DN2 min.		H mm	L max. mm
mm	inches	mm	inches		
15	1/2"	32	1 1/4"	150	5000
20	3/4"	40	1 1/2"	150	5000
25	1"	50	2"	150	5000
32	1 1/4"	65	2 1/2"	150	5000
40	1 1/2"	65	2 1/2"	150	5000
50	2"	80	3"	150	5000
65	2 1/2"	100	4"	150	5000
80	3"	100	4"	150	5000
100	4"	125	5"	150	5000
150	6"	200	8"	150	5000

### LINING

- ▶ **VIRGIN PTFE :** DN 15 - DN 150
- ▶ **ANTISTATIC PTFE, C4 = A :** DN 15 - DN 150

Other special dip pipes are available on request.



GLOBAL EXPERT IN ELECTRICAL  
POWER AND ADVANCED MATERIALS

**EUROPE**

**FRANCE**

Mersen France Py S.A.S.  
Tel : +33 (0)3 83 81 60 81  
info.pagny@mersen.com

**GERMANY**

Mersen Deutschland  
Linsengericht GmbH  
Tel : +49 (0) 6051 71 037  
info.lsg@mersen.com

**ITALIA**

Mersen Italia S.p.A.  
Tel : +39 02 82 681 31  
ace.italia@mersen.com

**SPAIN**

Mersen Iberica fma, S.A.  
Tel : +34 93 685 7800  
contact.iberica@mersen.com

**THE NETHERLANDS**

Mersen Benelux B.V.  
Tel : +31(0)10 298 30 30  
contact.schiedam@mersen.com

**UNITED KINGDOM**

Mersen UK Teesside Ltd.  
Tel : +44 (0)1642 790100  
ace.uk@mersen.com

**RUSSIA & EASTERN EUROPE**

Tel : +7 (964) 768 14 05  
info.pagny@mersen.com

**TURKEY**

Mersen Istanbul San. Ür. A. Ş.  
Tel : +90 262 751 0262  
sales.istanbul@mersen.com

**ASIA**

**CHINA**

Mersen XIANDA  
Tel : +86 21 5752 7777  
info.xianda@mersen.com

**INDIA**

Mersen India  
Tel : +91 9845331292  
/+91 9840078844  
sales.ace.india@mersen.com

**JAPAN**

MERSEN FMA JAPAN K.K.  
Tel : +81 (3) 5368-3250  
ace.japan@mersen.com

**KOREA**

Mersen Korea Co., Ltd.  
Tel : +82 (0)2 598 0071  
sales.korea@mersen.com

**SOUTH EAST ASIA**

Tel : +91 9500041487  
graphite.sales@framet.com

**NORTH AMERICA**

**USA**

Mersen USA Salem  
Tel : +1 540 389-7535  
sales.salem@mersen.com

**Mersen USA Gonzales**

Tel : +1 225 647-6752  
graphiterepairs.gonzales@mersen.com

**AFRICA**

**MOROCCO**

Mersen Maroc S.A.R.L.  
Tel : + 212 (0) 523 38 30 12  
contact.maroc@mersen.com

**SOUTH AFRICA**

Mersen South Africa, (Pty) Ltd.  
Tel : +27 011 474 0000  
marketing.za@mersen.com

**MIDDLE EAST & AFRICA**

Tel : +33 (0)3 83 81 60 81  
Info.pagny@mersen.com

**SOUTH AMERICA**

**ARGENTINA**

Mersen Argentina, S.A.  
Tel : +54 11 49 18 21 21  
infos.latam@mersen.com

**BRAZIL**

Mersen Do Brasil, Ltda.  
Tel : +55 (11) 4529 1160  
vendas.ace.brasil@mersen.com

**CHILE**

Mersen Chile  
Tel : +56 22 621 5680  
ventas.chile@mersen.com

**COLOMBIA**

Mersen Colombia  
Tel : +57 (1) 3684588  
ace.latam@mersen.com

**MEXICO & LATIN AMERICA**

Mersen Mexico Monterrey  
Tel : +52 (81) 8127 2812  
ace.latam@mersen.com

